



03T.3

SECURY AUTOMATIC DOOR LOCK & GRIPSET HANDLE

SECURY Automatic Cutout.....	03T.3.2
SECURY Automatic Extension Cutout.....	03T.3.3
Reverse Latches & Connect Automatic Extension.....	03T.3.4
Keepers	03T.3.5
BERKELEY Gripset Handle Dimensions.....	03T.3.8
Gripset Handle Cutout	03T.3.9
Accessories	03T.3.10
Mounting and Installation Instructions	03T.3.11
Gripset Handle Dummy Conversion Instructions	03T.3.26
Gripset 1 3/4" Conversion Instructions	03T.3.27
Gripset 2 1/4" Conversion Instructions	03T.3.28
Gripset 2 3/4" Conversion Instructions	03T.3.29
Gripset 3" Conversion Instructions	03T.3.30

Door Multi-point Locking System

SECURY Automatic Door Lock for Gripset

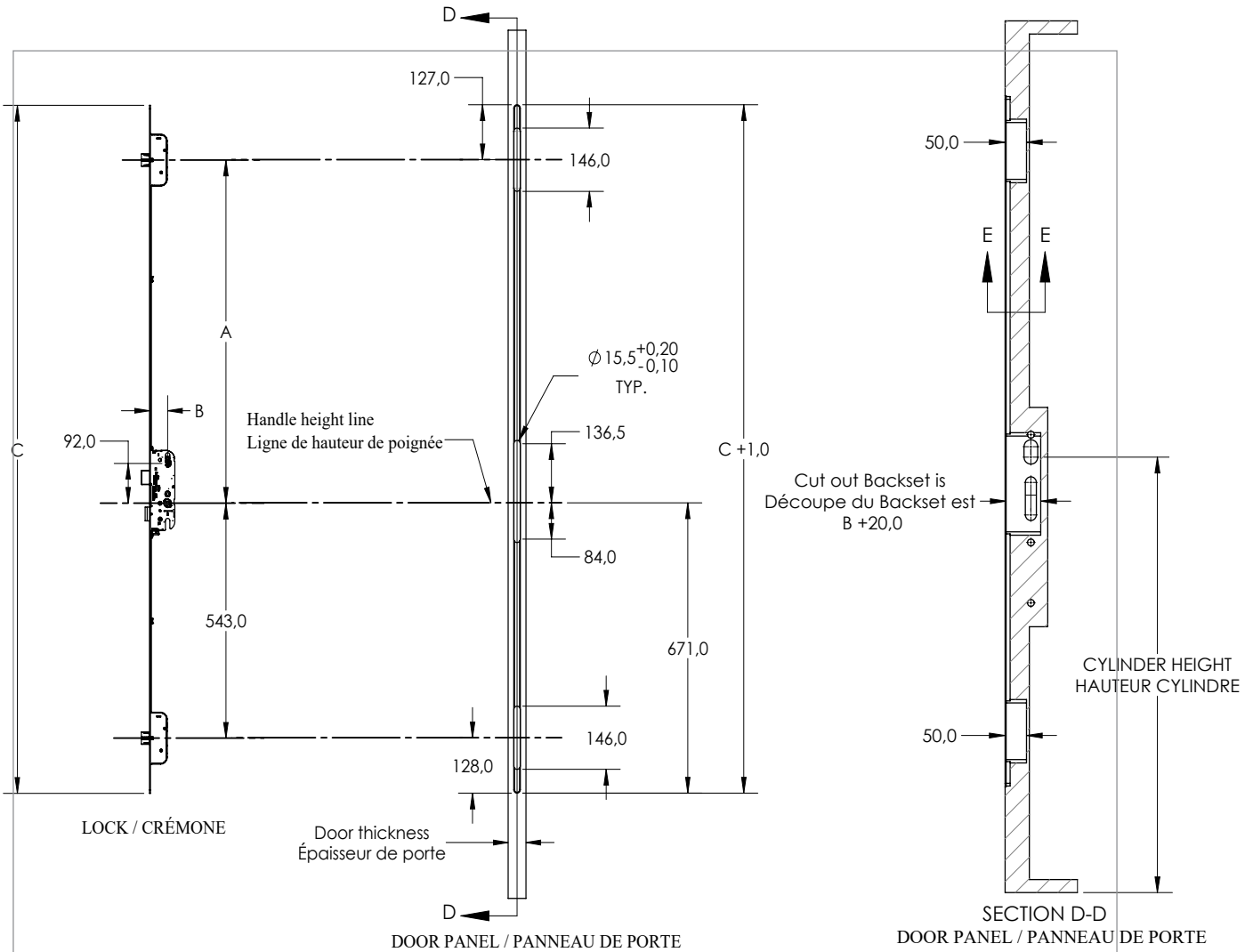

03
3

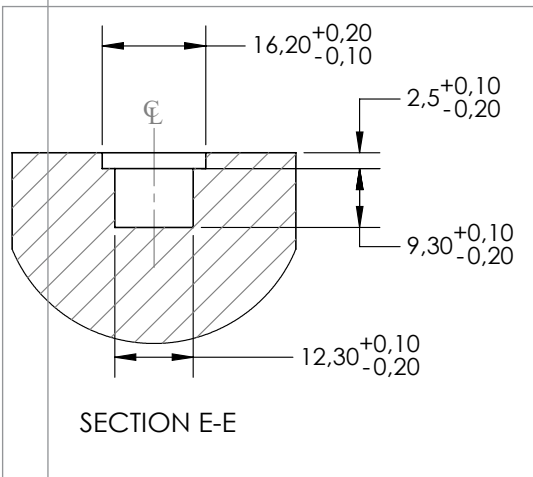

Reference number	B	A	C
6-35185-01-R-8B	60 mm	792 mm	1590 mm
6-35185-02-R-8B	60 mm	1102 mm	1900 mm
6-35185-03-R-8B	70 mm	792 mm	1590 mm
6-35185-04-R-8B	70 mm	1102 mm	1900 mm

Notes:

When using lever handle operation, please check handle height first
All dimensions must be verified on a prototype before production
Observe the proper slab to jamb clearance of 3-4mm

Veillez d'abord vérifier la hauteur de la poignée avant d'utiliser la poignée à levier,
Toutes les dimensions doivent être vérifiées sur un prototype avant production
Respectez 3 à 4 mm de dégagement entre la porte et le montant de porte

Door Multi-point Locking System

Extensions for SECURY Automatic Door Lock



Reference number	D
6-33479-04-0-8B	525 mm
6-C5078-00-0-8B	800 mm

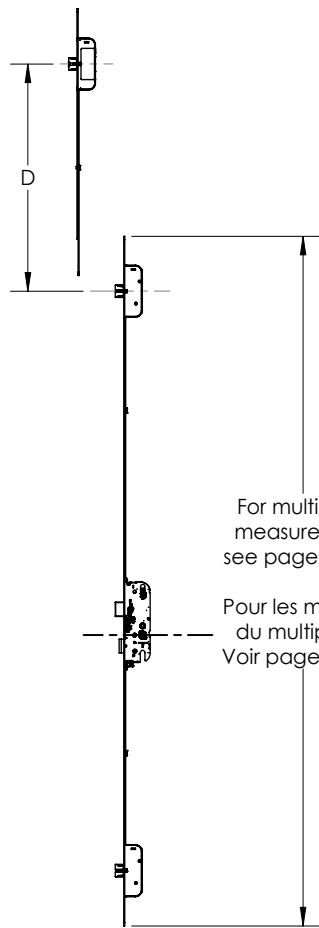

For multipoint measurement see page 1 - "C"

Pour les mesures du multipoint, Voir page 1 - "C"

LOCK / CRÉMONE

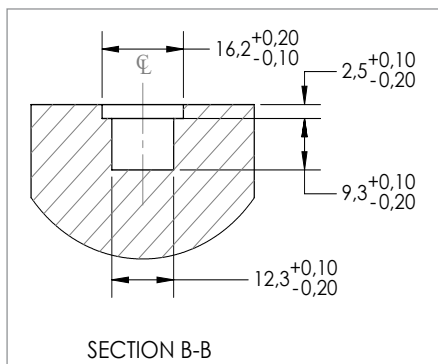
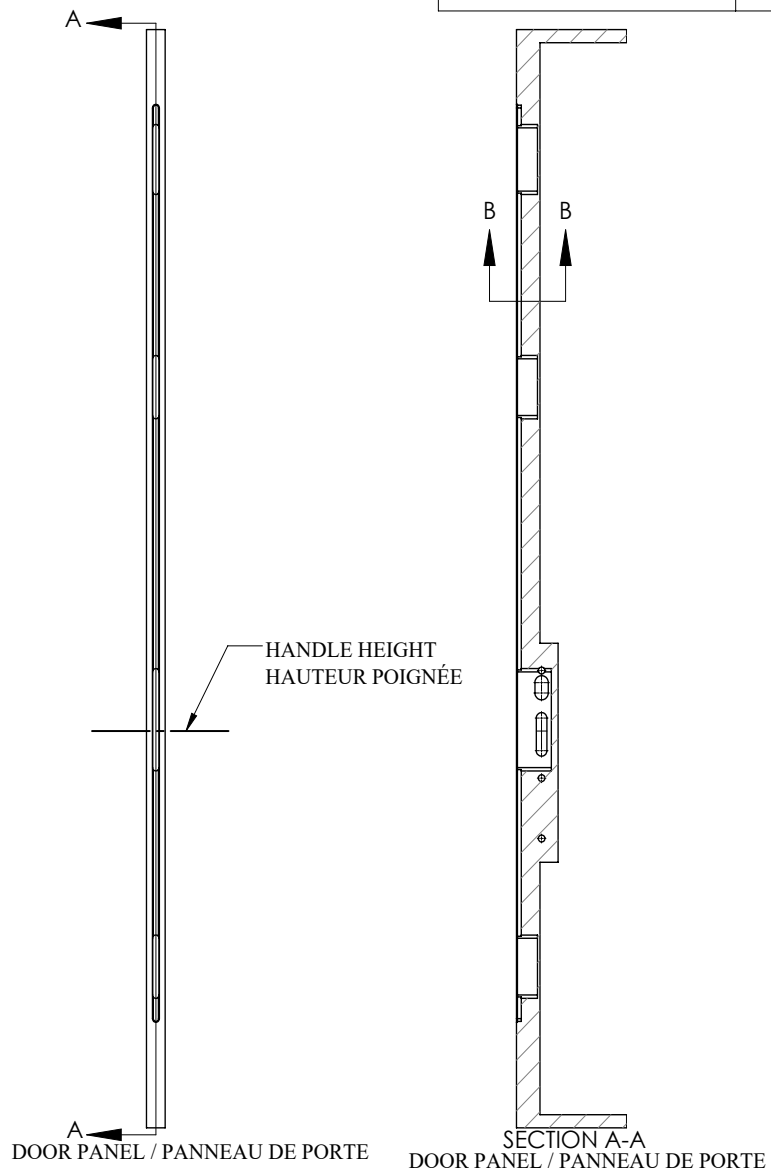

SECTION B-B

Notes:

All dimensions must be verified on a prototype before production
Observe the proper slab to jamb clearance of 3-4mm

Toutes les dimensions doivent être vérifiées sur un prototype avant production
Respectez 3 à 4 mm de dégagement entre la porte et le montant de porte

03
3

Door Multi-point Locking System

How to Reverse Latches & Connect Extension to Door Lock



REVERSE LATCH (Use flathead screwdriver)

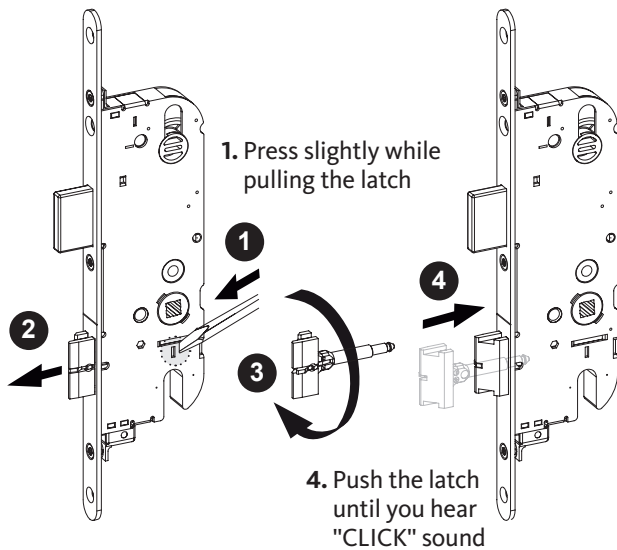

REVERSE AUTOMATIC LATCHES (Use 4mm Allen T-key H-00345-04-0-0)

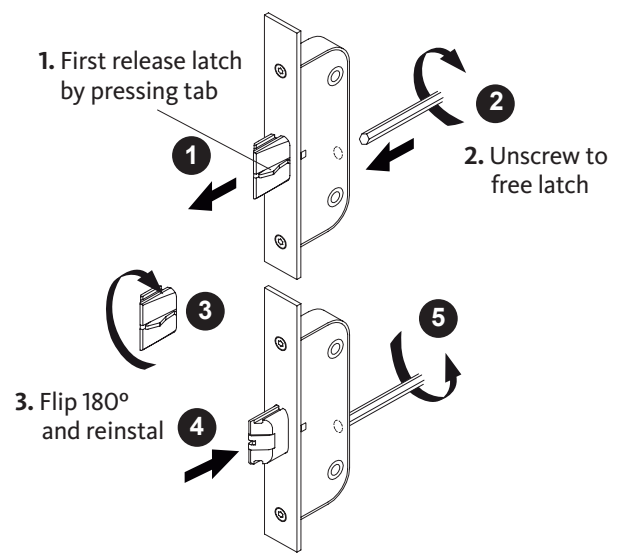

03
3

CONNECT SH2 & AUTOMATIC EXTENSIONS TO DOOR LOCK (Use Torx 15 T-key H-00346-15-0-0)

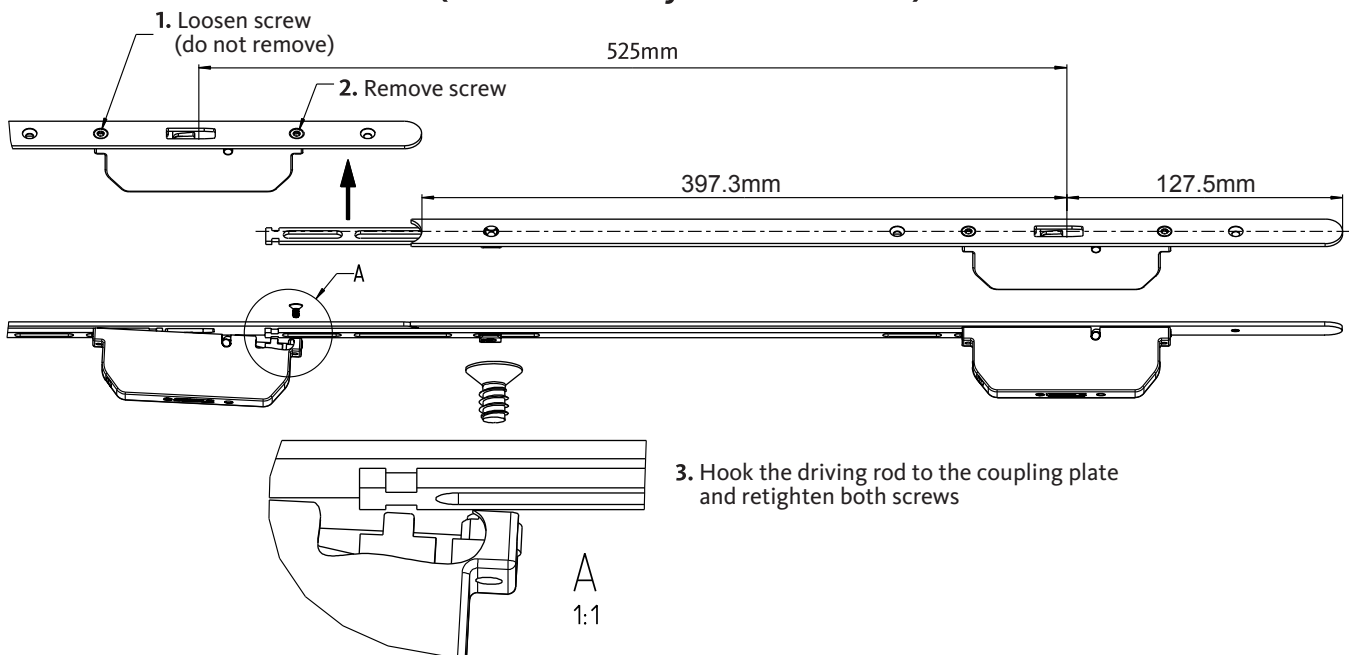



Top & Bottom Keeper

Description	Part Number
Keeper for 45mm (1 3/4") thick doors	9-C4776-45-0-*
Keeper for 57mm (2 1/4") thick doors	9-C4776-57-0-*

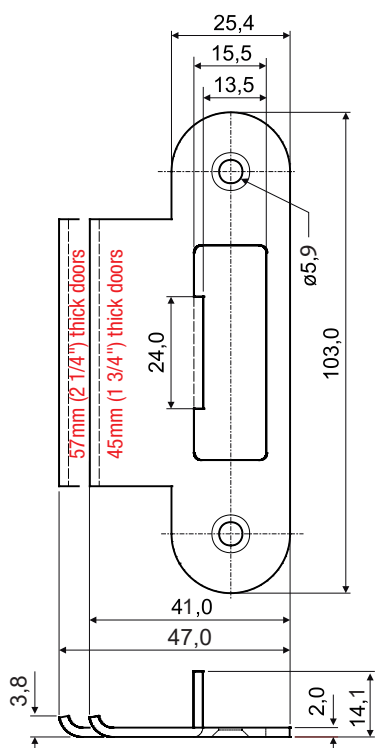

Middle Keeper

Description	Part Number
Keeper for 45mm (1 3/4") thick doors	9-C4777-45-0-*
Keeper for 57mm (2 1/4") thick doors	9-C4777-57-0-*

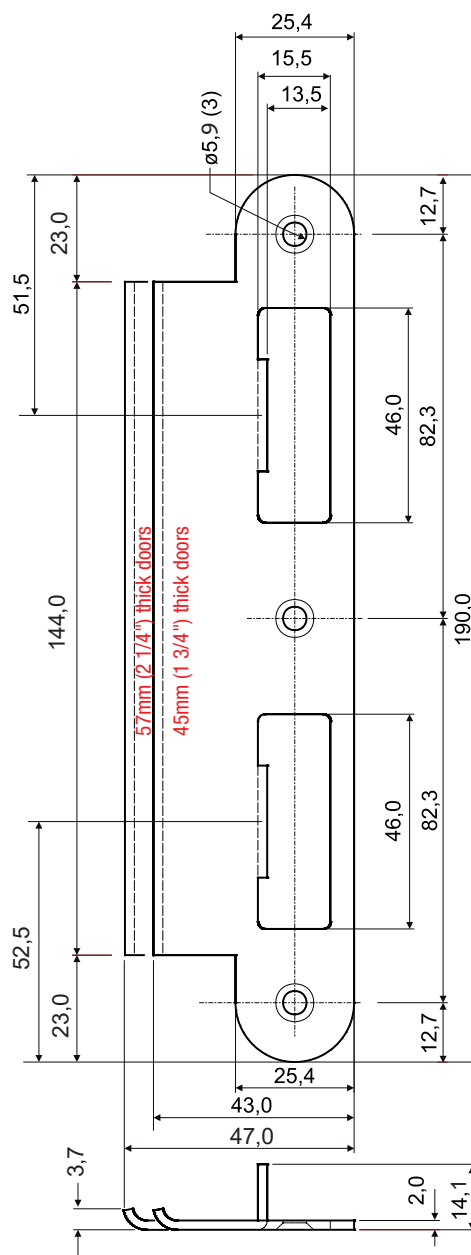



Top & Bottom Keeper

Description	Part Number
Keeper for 76mm (3") thick doors	9-C4716-59-0-8B

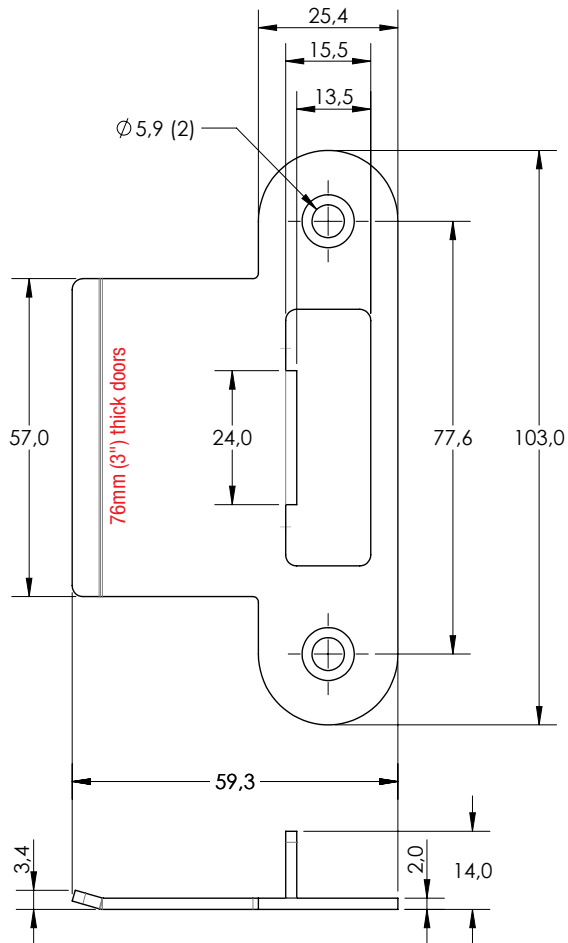

Middle Keeper

Description	Part Number
Keeper for 76mm (3") thick doors	9-C4717-59-0-8B

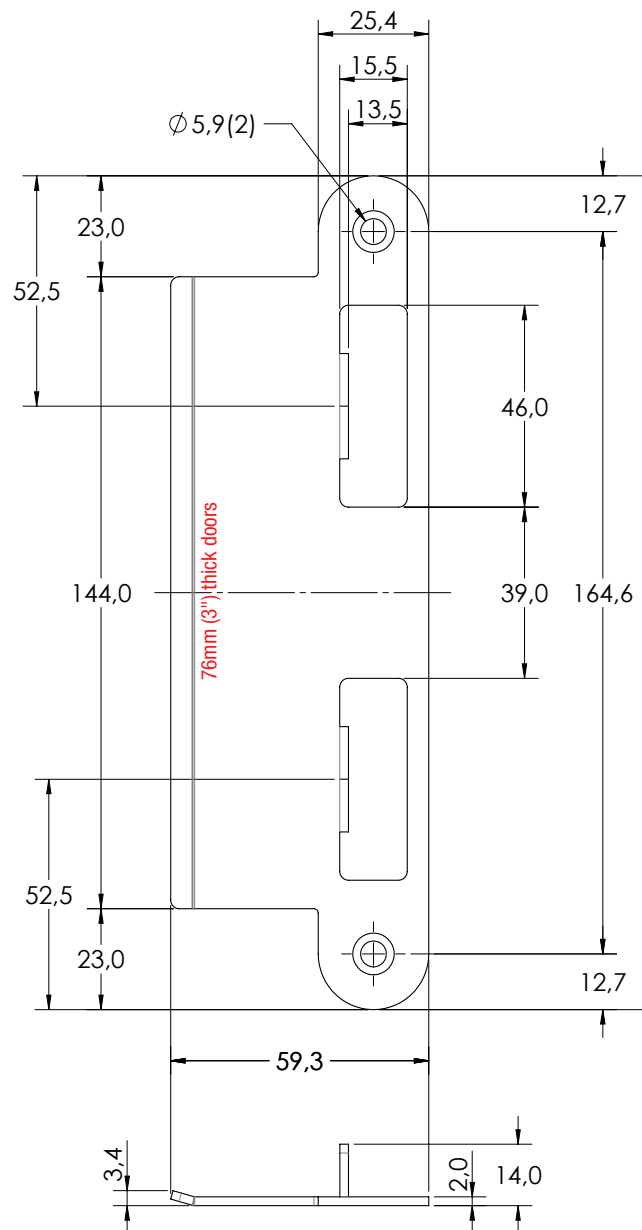

Door Multi-point Locking System

Keepers

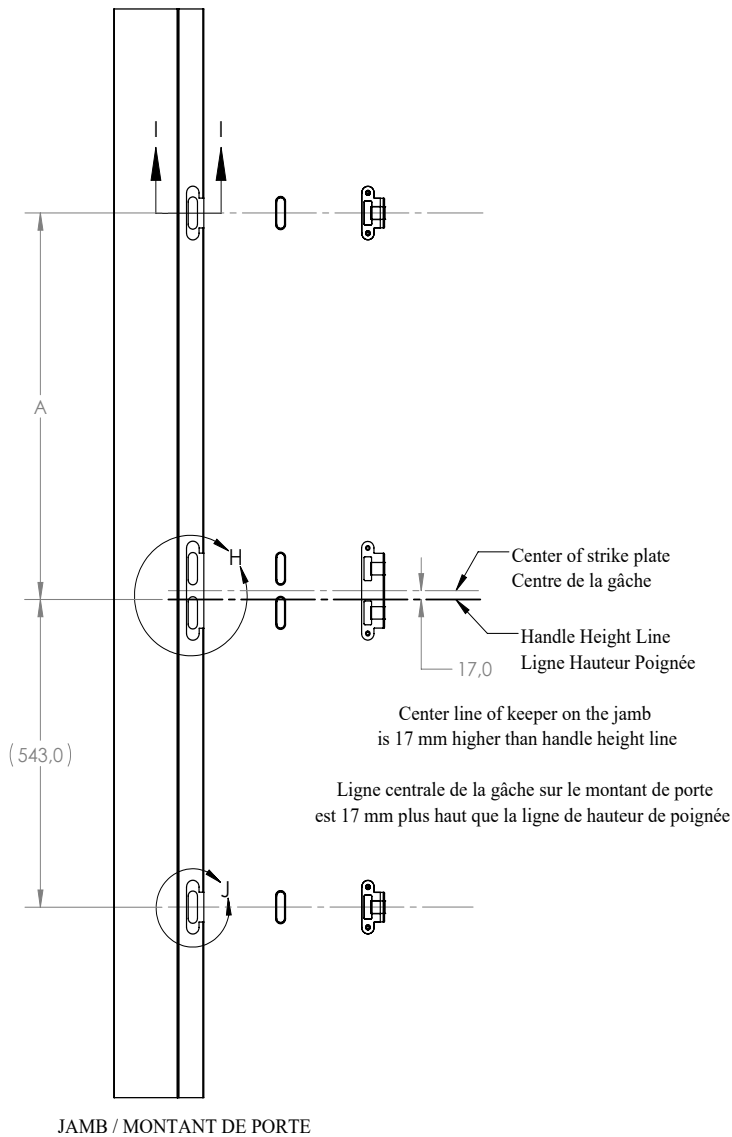

JAMB / MONTANT DE PORTE

Door Thickness	G
1 3/4"	22,5 mm
2 1/4"	28,5 mm
3"	38,0 mm

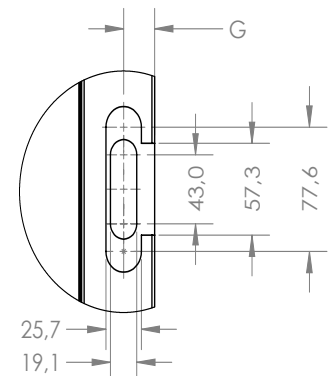

2X DETAIL J

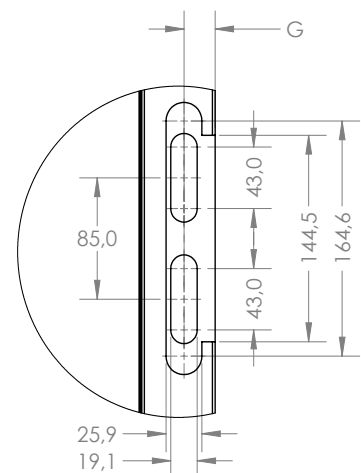

DETAIL H

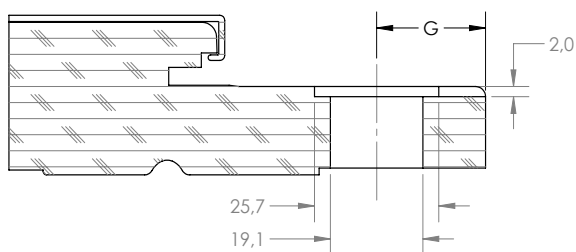

SECTION I-I

Note:

Center line of door lock will position itself with the center line of the strike plate measurement - G
 Keepers' position must be as specified, otherwise it could alter the locking
 Latches should engage in the keepers without friction

La ligne centrale de la serrure de porte se positionnera avec la ligne centrale de la gâche - G
 La position des gâches doit être telle que spécifiée, sinon elle pourrait modifier le verrouillage
 Les pènes doivent s'engager dans les gâches sans friction

03
3

Door Multi-point Locking System

BERKELEY Gripset Handle Dimensions



BERKELEY

Description	Part Number
Gripset handle	K-C2070-00-0-*

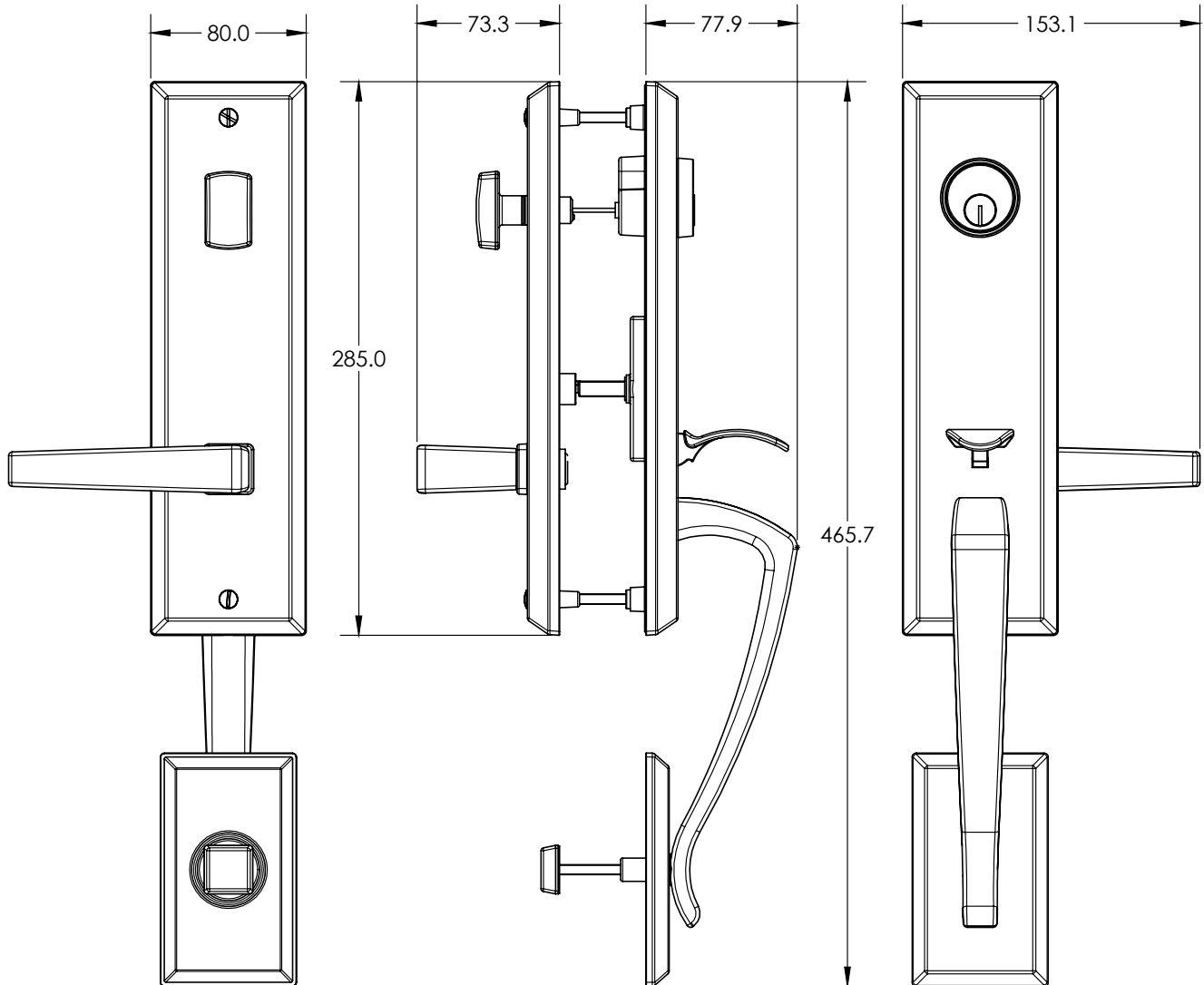



Construction Key

Description	Part Number
Construction key	9-U0001-01-0-0

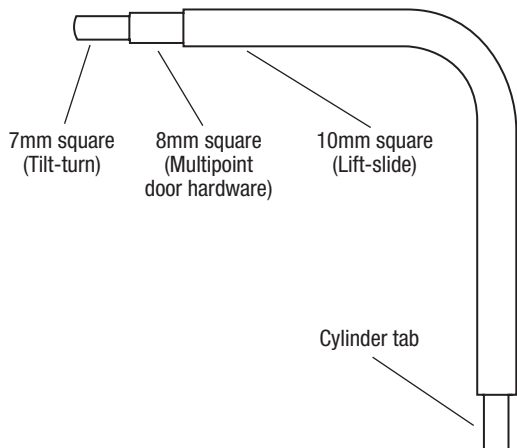

Plastic Cup - With Edge

Description	Part Number
Plastic cup	9-C4765-00-0-6

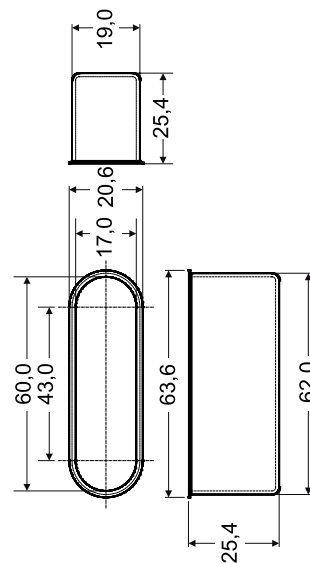

Plastic Cup - No Edge

Description	Part Number
Plastic cup	9-C4765-00-A-6

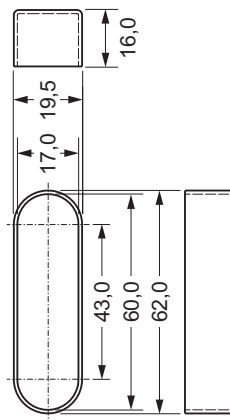

Door Multi-point Locking System

Mounting and Installation Instructions For BERKELEY

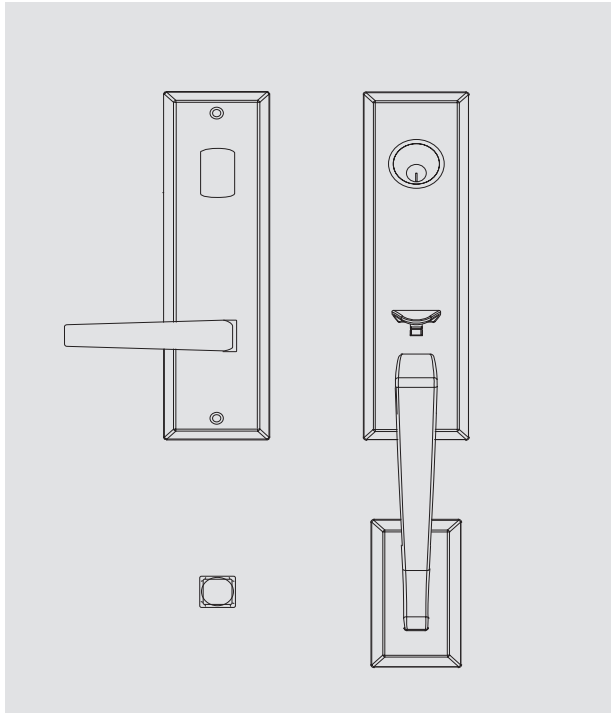

What's in the box

Pos	Qty	Description
①	1	Interior plate with knob
②	1	Exterior handle set with cylinder, actuator and gasket
③	1	Interior handle with set screw
④	1	Set of two keys
⑤	2	M5 x 65mm installation screws for 1 3/4" doors
	2	M5 x 75mm installation screws for 2 1/4" doors
⑥	1	M5 x 45mm bottom screw for 1 3/4" doors
	1	M5 x 60mm bottom screw for 2 1/4" doors
⑦	1	Bottom screw washer
⑧	1	Bottom screw cover with set screw
⑨	1	Handle nylon washer
⑩	1	Allen key 2,5mm x 100mm

03
3

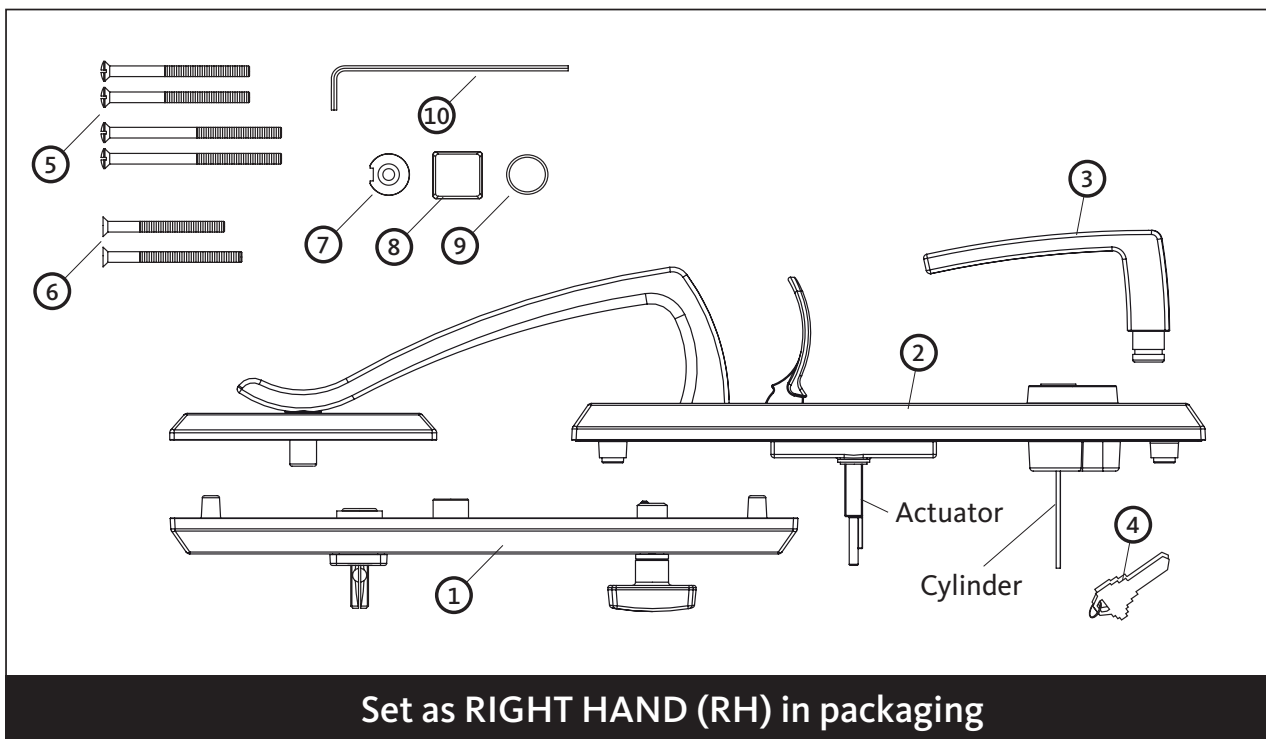

Door Multi-point Locking System

Mounting and Installation Instructions For BERKELEY - Door Thicknesses



**DOOR THICKNESS
45mm (1 3/4")**

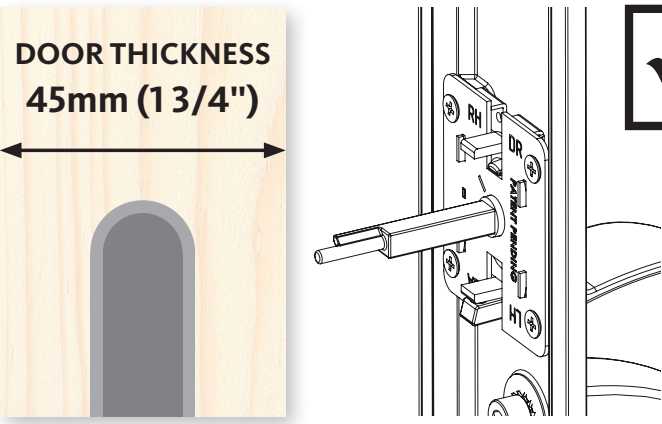

INCLUDED

**ACTUATOR
MOUNTED
ON THE
EXTERIOR
PLATE**



**DOOR THICKNESS
57mm (2 1/4")**

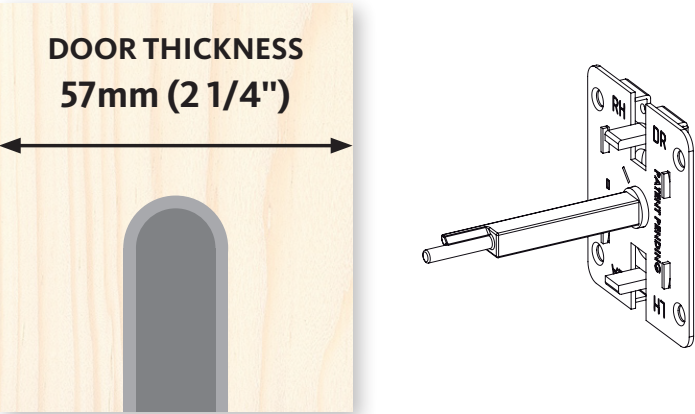

**SOLD
SEPARATELY**

**ACTUATOR KIT
K-C2054-57-0-0**

**DOOR THICKNESS
76mm (3")**

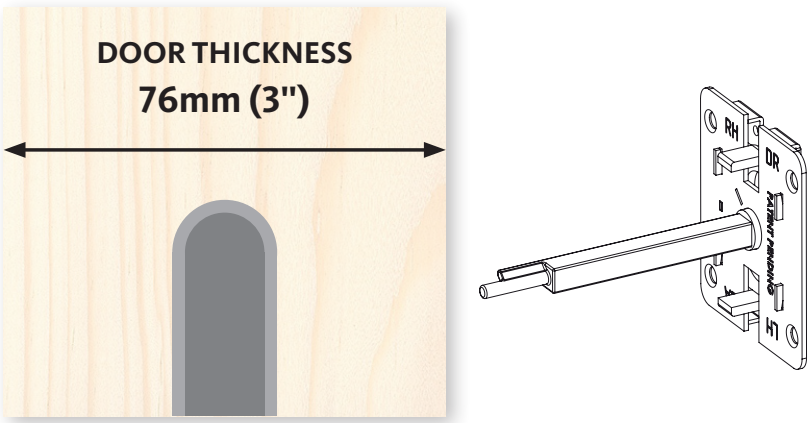

**SOLD
SEPARATELY**

**ACTUATOR KIT
K-C2054-76-0-0**

Door Multi-point Locking System

Mounting and Installation Instructions For BERKELEY - Door Openings



INSIDE

OUTSIDE

INSIDE

OUTSIDE

LH

LEFT HANDED DOOR

START STEP 1

INSIDE

OUTSIDE

INSIDE

OUTSIDE

RH

RIGHT HANDED DOOR

GO TO STEP 5

03
3

Door Multi-point Locking System

Mounting and Installation Instructions For BERKELEY



STEP 1

REMOVE
THE GASKET

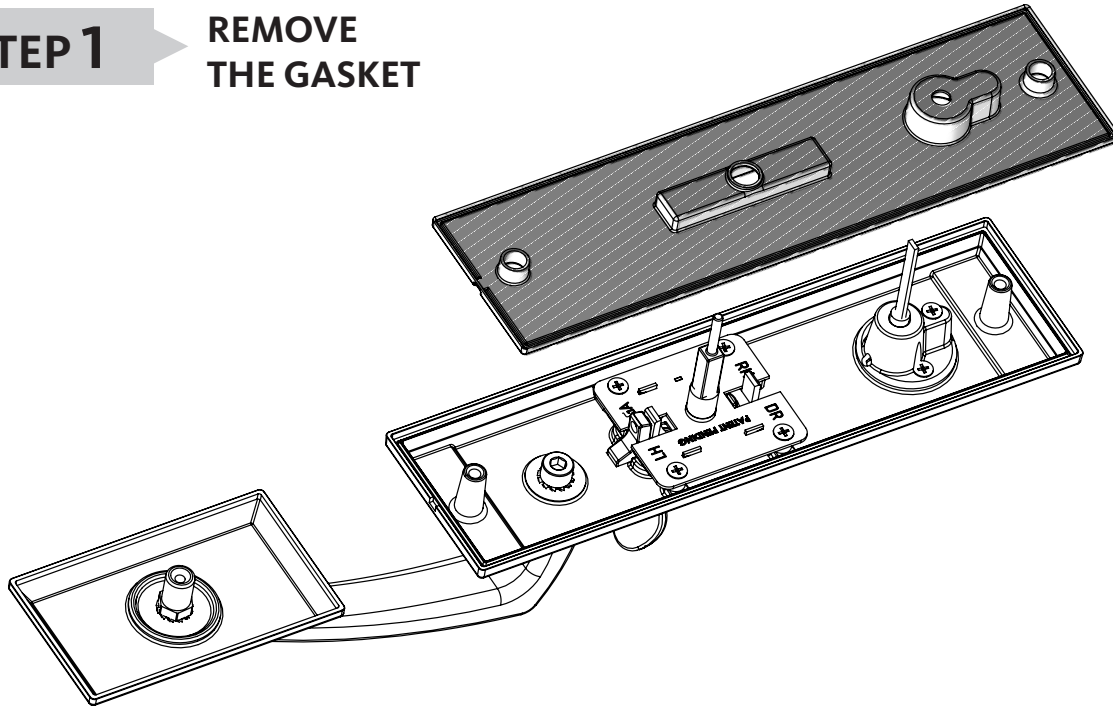

STEP 2

REMOVE THE
4 SCREWS

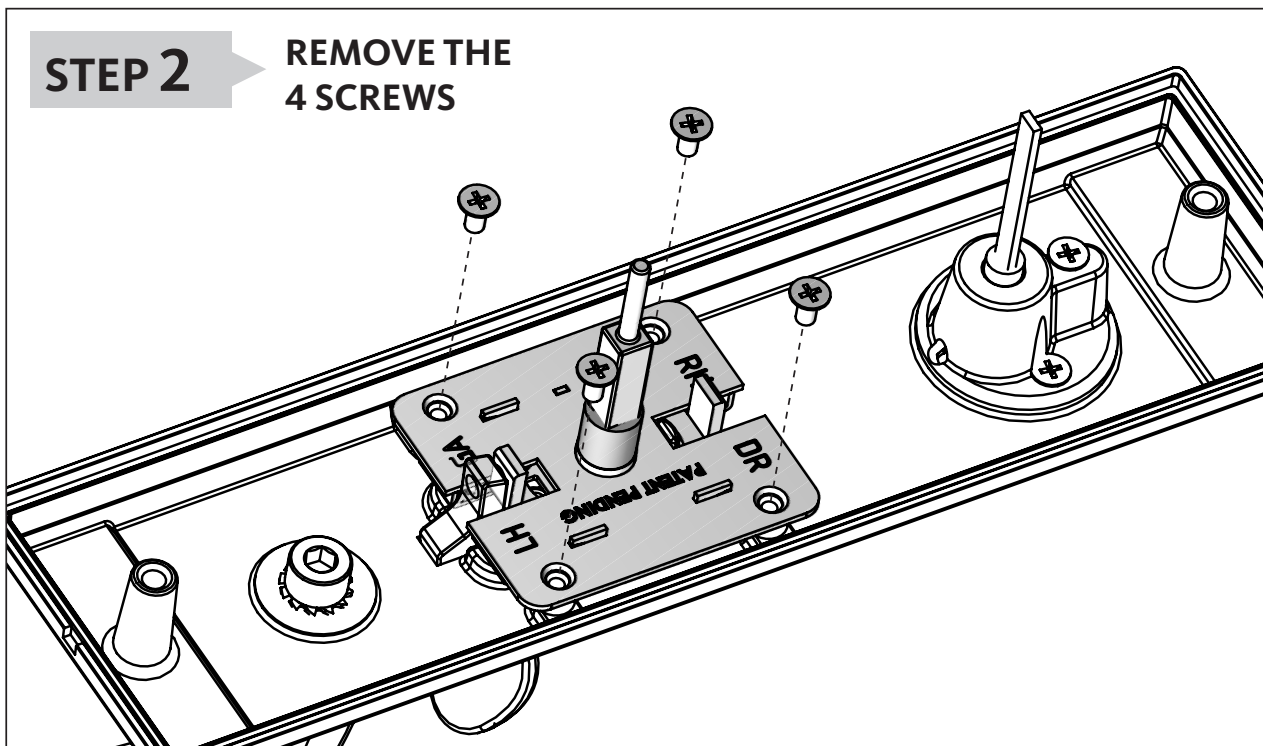

Door Multi-point Locking System

Mounting and Installation Instructions For BERKELEY



STEP 3

**TURN THE ACTUATOR
180 DEGREES TO SET
LEFT HAND (LH)**

LH

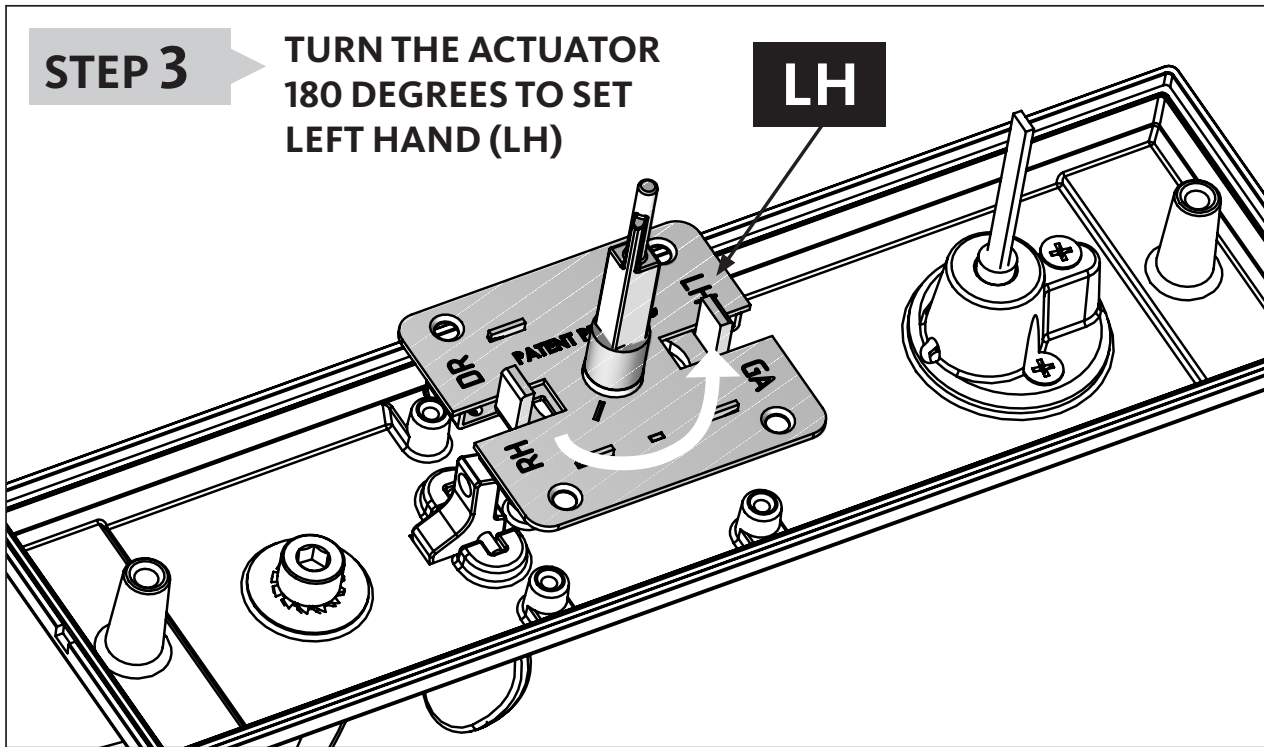

03
3

STEP 4

**INSERT AND TIGHTENED
THE 4 SCREWS AND THEN
REPOSITION THE GASKET**

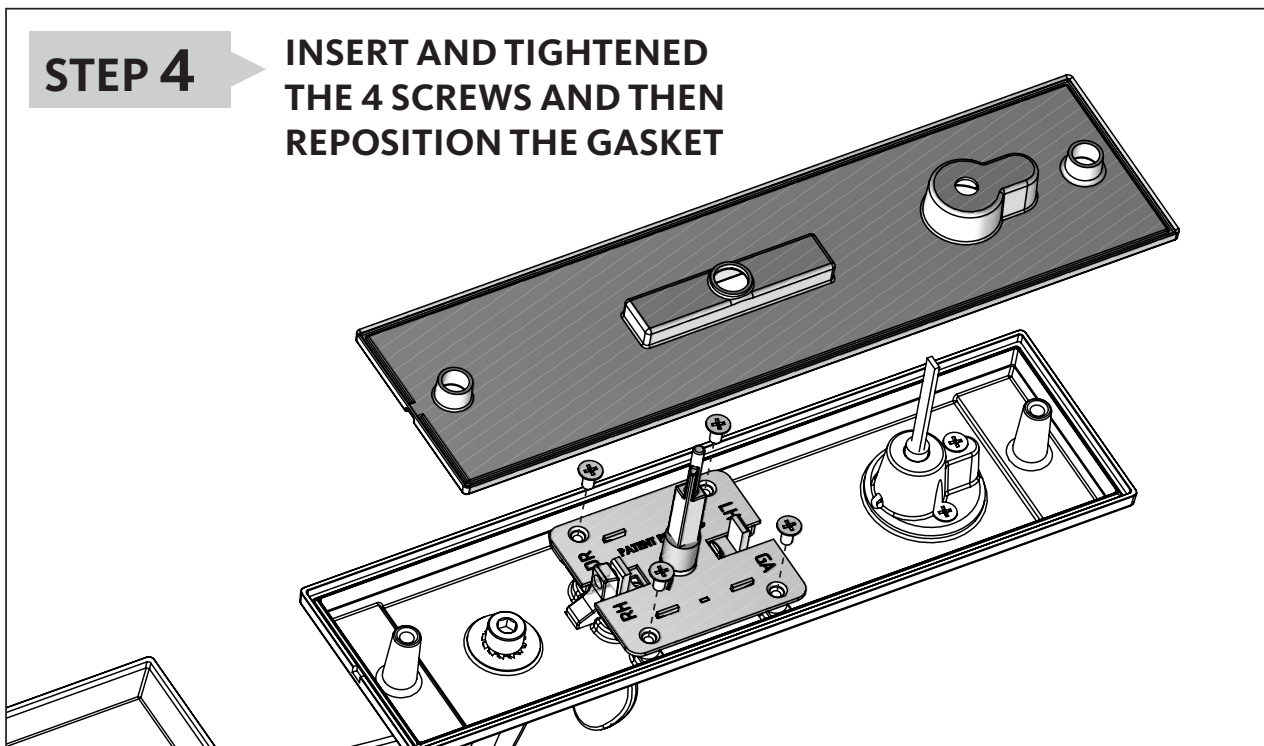



STEP 5

PLACE THE NYLON WASHER
OVER THE HANDLE SHAFT

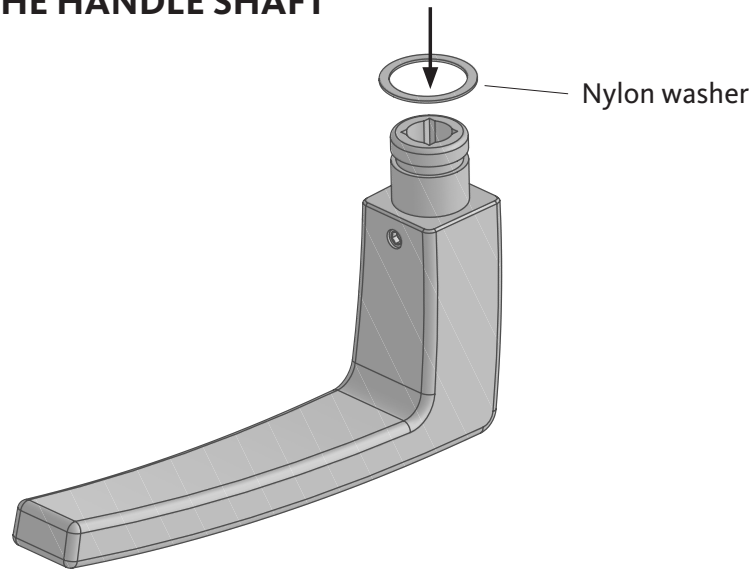

03
3

STEP 6

LOOSEN THE SET SCREW WITH
2,5mm ALLEN KEY

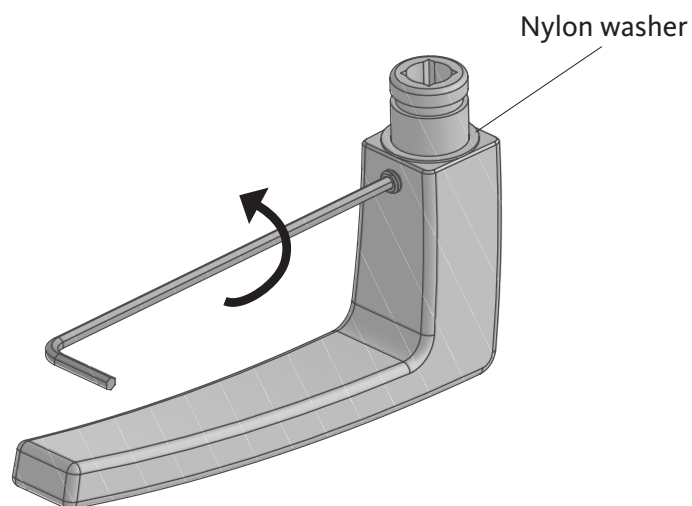

Door Multi-point Locking System

Mounting and Installation Instructions For BERKELEY



STEP 7

**PLACE THE HANDLE
OVER THE SPINDLE**

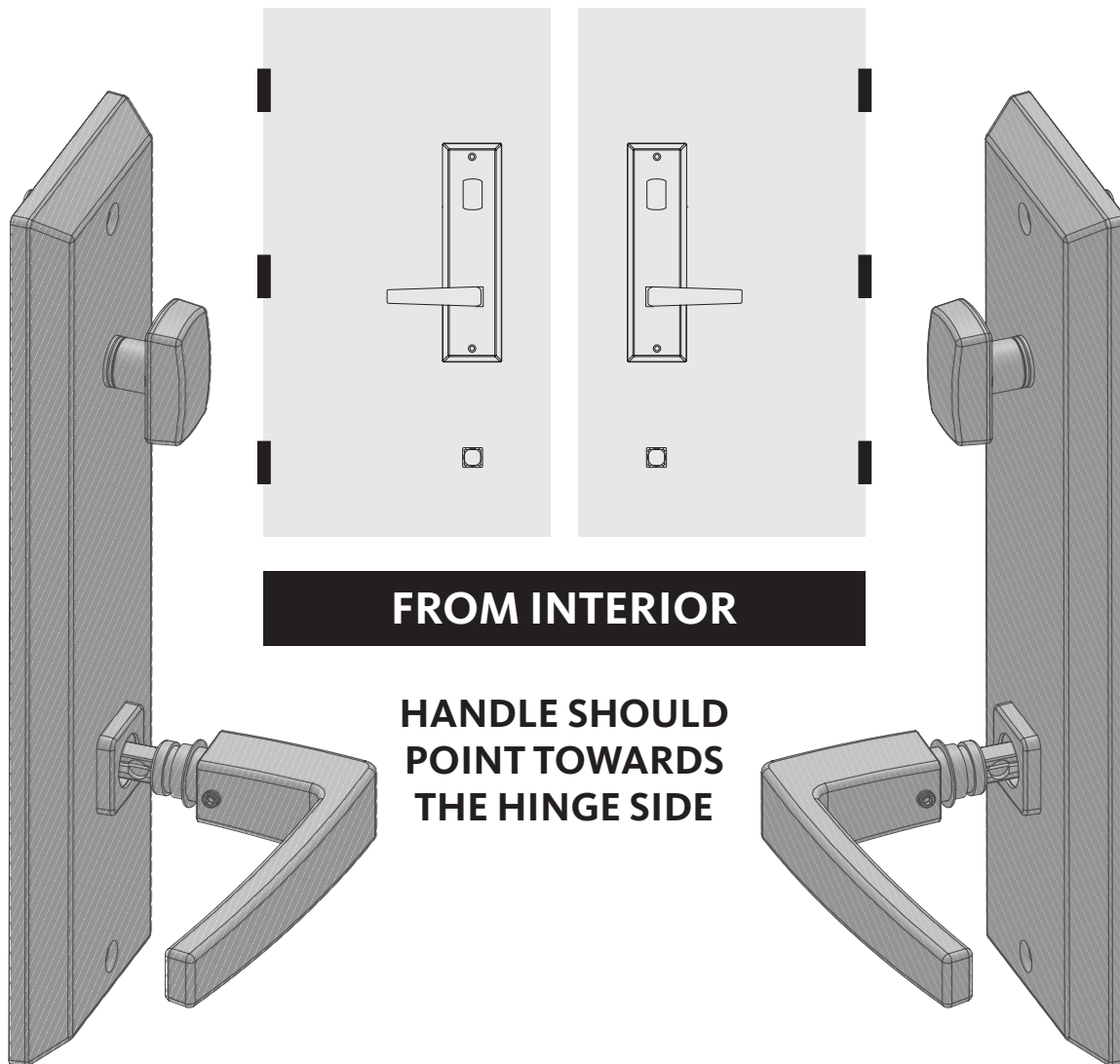

03
3

Door Multi-point Locking System

Mounting and Installation Instructions For BERKELEY

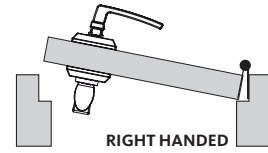

STEP 8

COMPRESS BACK END OF THE SPINDLE (A) AND HANDLE (B) TOGETHER AND SECURELY TIGHT THE SET SCREW. TEST THE HANDLE!

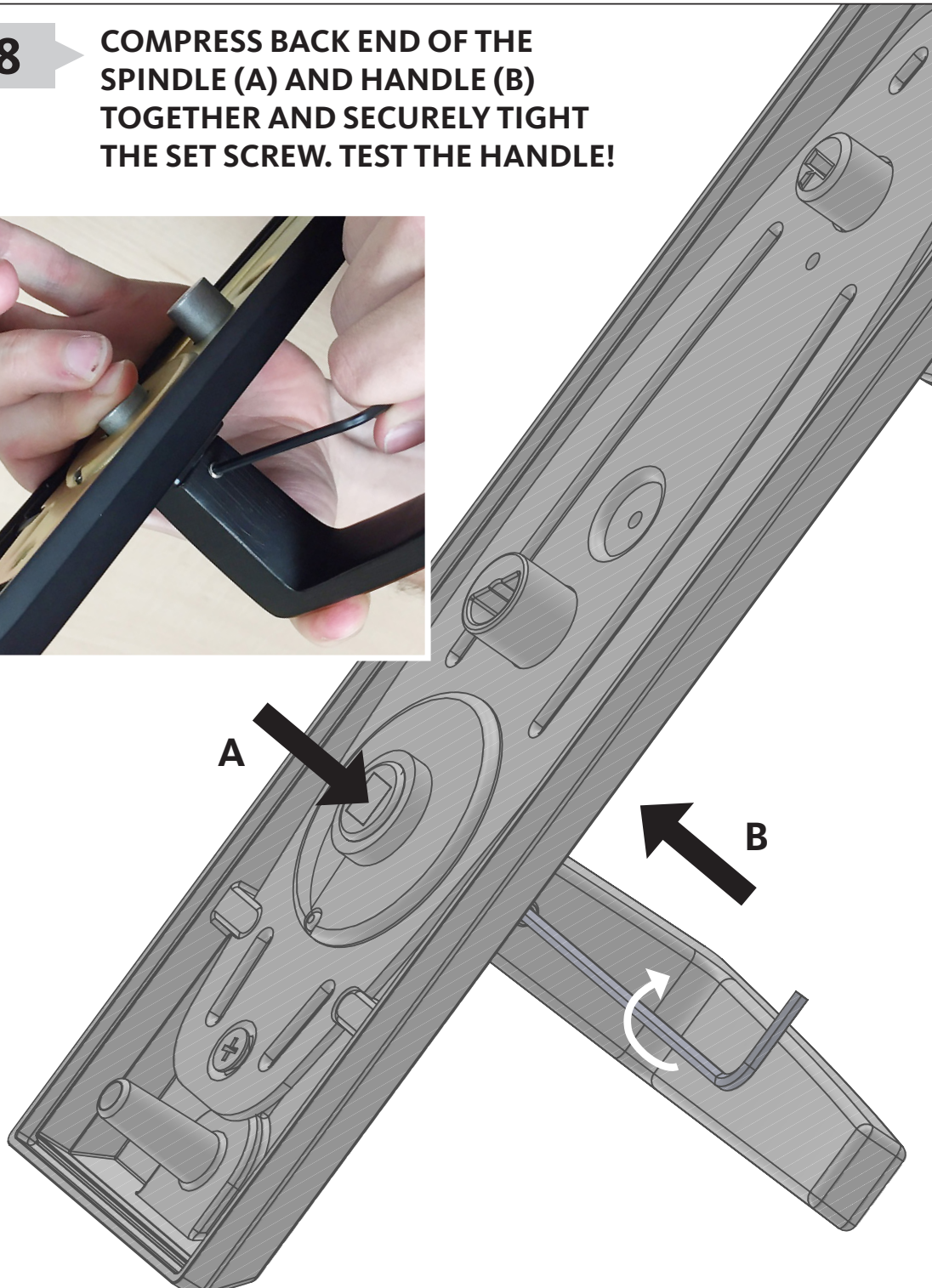

Door Multi-point Locking System

Mounting and Installation Instructions For BERKELEY

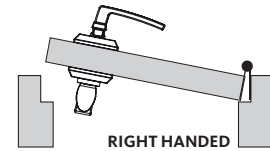

STEP 9

POSITION THE EXTERIOR HANDLE ASSEMBLY IN FRONT OF THE CUTOUTS

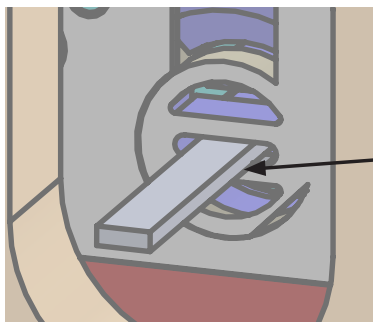

PUSH THE CYLINDER TAIL THROUGH THE CYLINDER SLOT

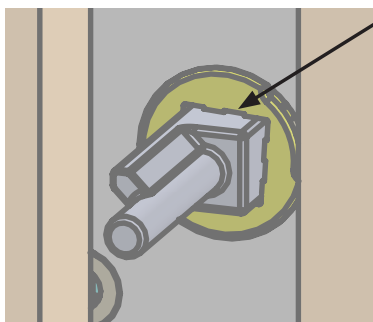

AT THE SAME TIME PUSH THE SPINDLE THROUGH THE SPINDLE HOLE OF THE DOOR GEAR

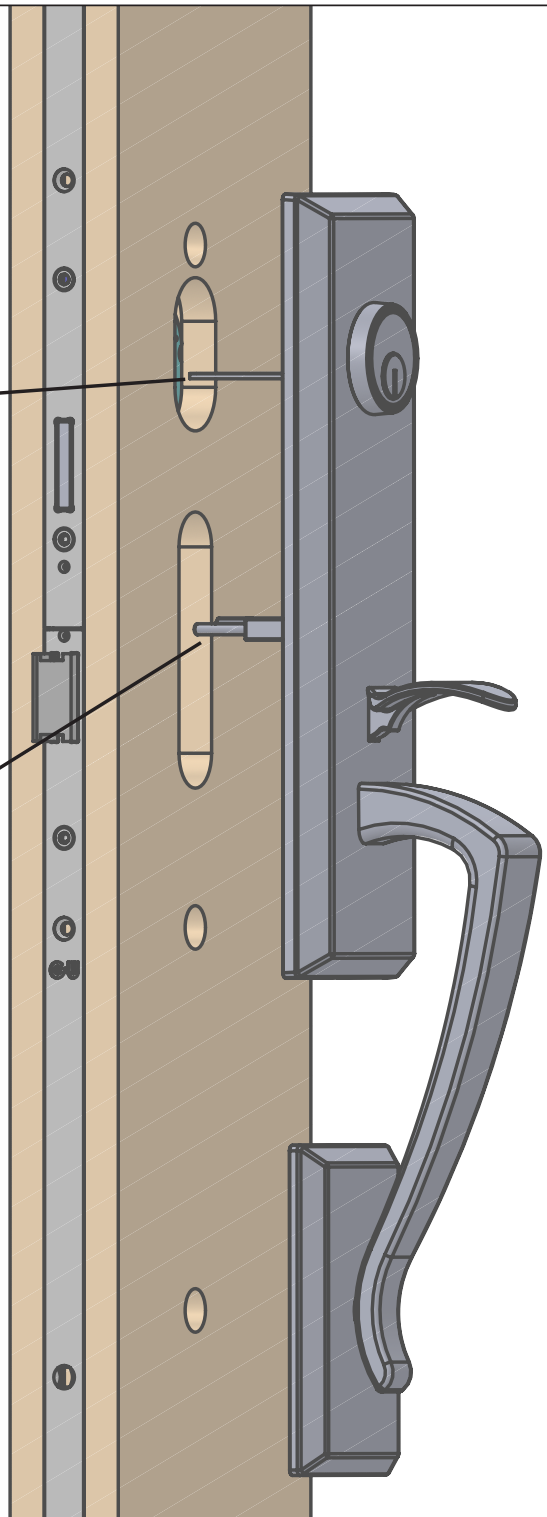

Door Multi-point Locking System

Mounting and Installation Instructions For BERKELEY

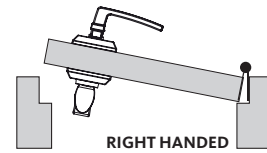

STEP 10 POSITION THE INTERIOR HANDLE ASSEMBLY IN FRONT OF THE CUTOUTS

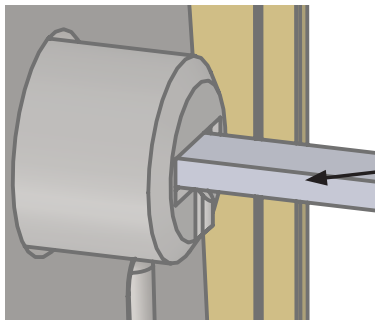

PLACE THE KNOB OVER THE CYLINDER TAIL PIECE

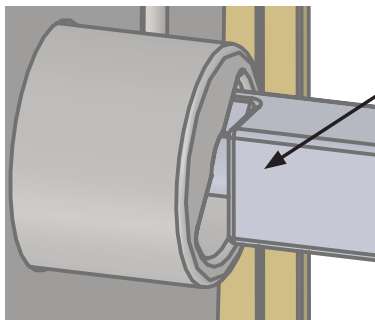

PLACE THE HOUSING OVER THE SPINDLE

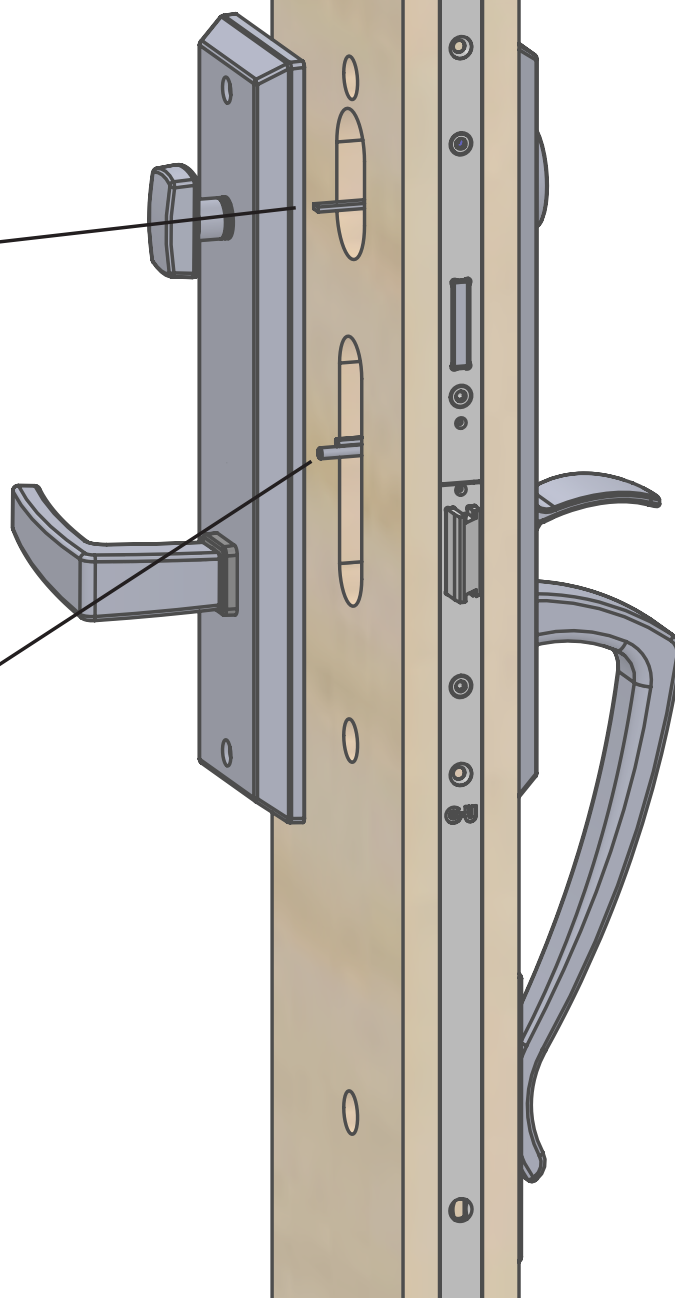

Door Multi-point Locking System

Mounting and Installation Instructions For BERKELEY

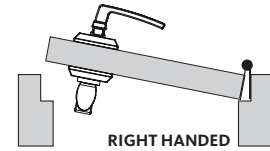

STEP 11

FASTEN THE INTERIOR ASSEMBLY TO THE EXTERIOR ASSEMBLY



USE TWO M5 X 65mm FOR 1 3/4" DOORS

USE TWO M5 X 75mm FOR 2 1/4" DOORS



USE M5 X 45mm FOR 1 3/4" DOORS

USE M5 X 60mm FOR 2 1/4" DOORS

SCREW WASHER

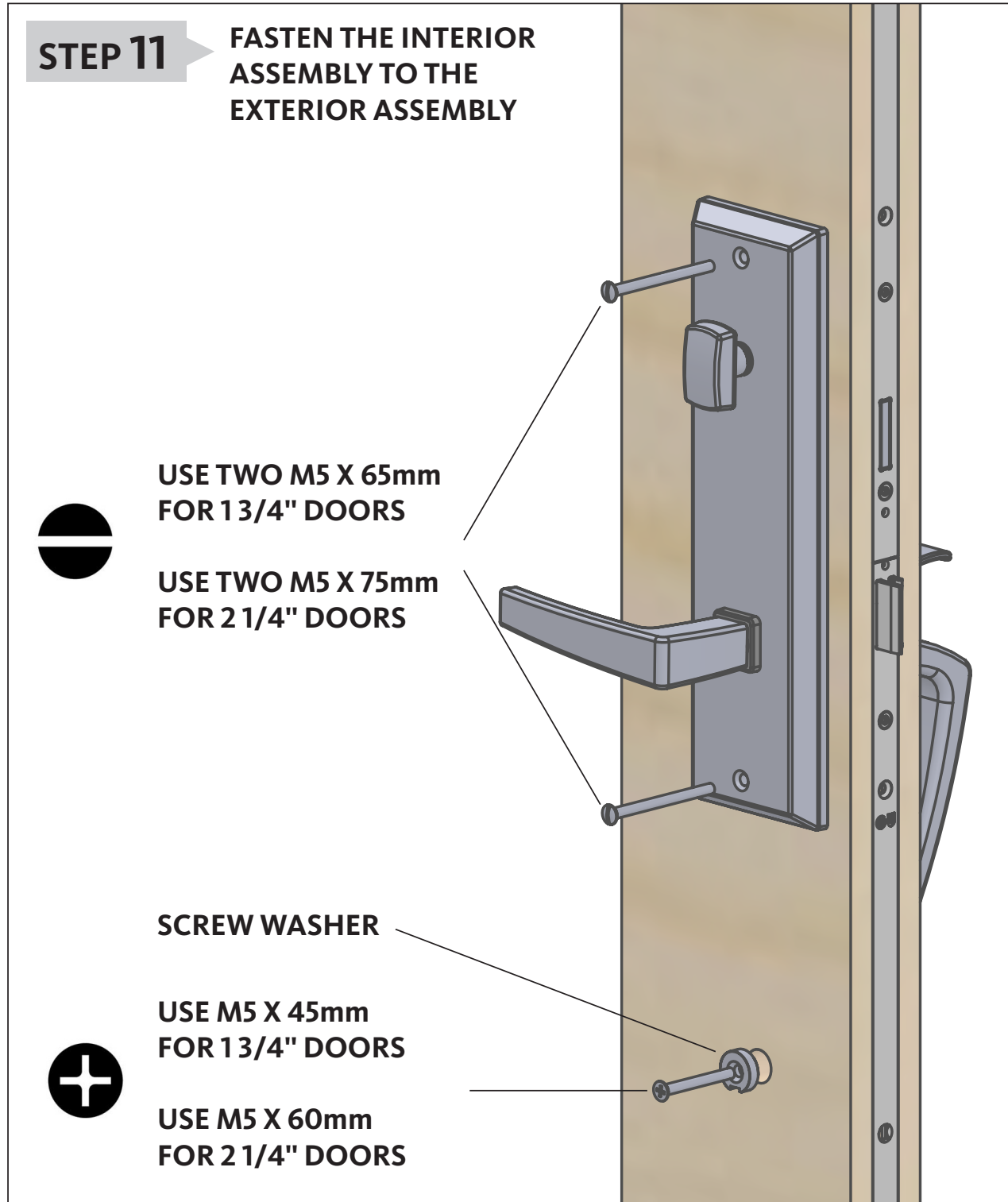

Door Multi-point Locking System

Mounting and Installation Instructions For BERKELEY

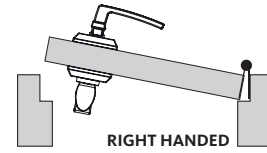

STEP 12

THE SLOT ON THE SCREW WASHER MUST FACE DOWN TO RECEIVE THE SET SCREW

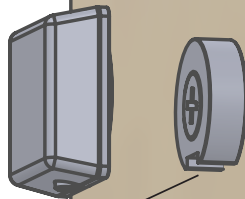

TIGHTEN THE SET SCREW WITH THE 2,5mm ALLEN KEY



Door Multi-point Locking System

Mounting and Installation Instructions For BERKELEY



STEP 13 KEEP DOOR OPEN WHEN TESTING THE OPERATION

OPEN THE DOOR

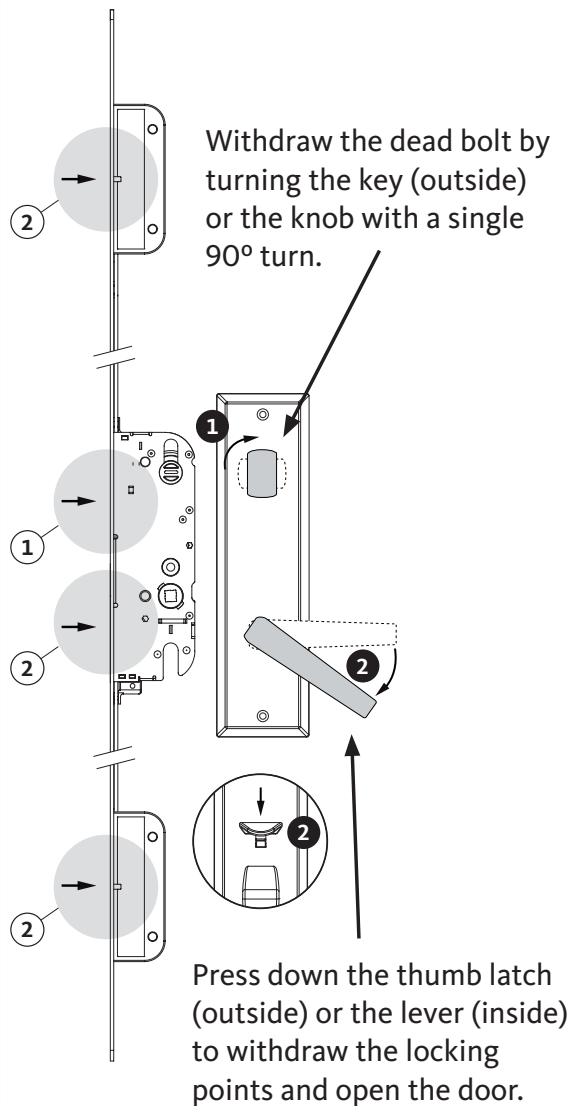

CLOSE THE DOOR

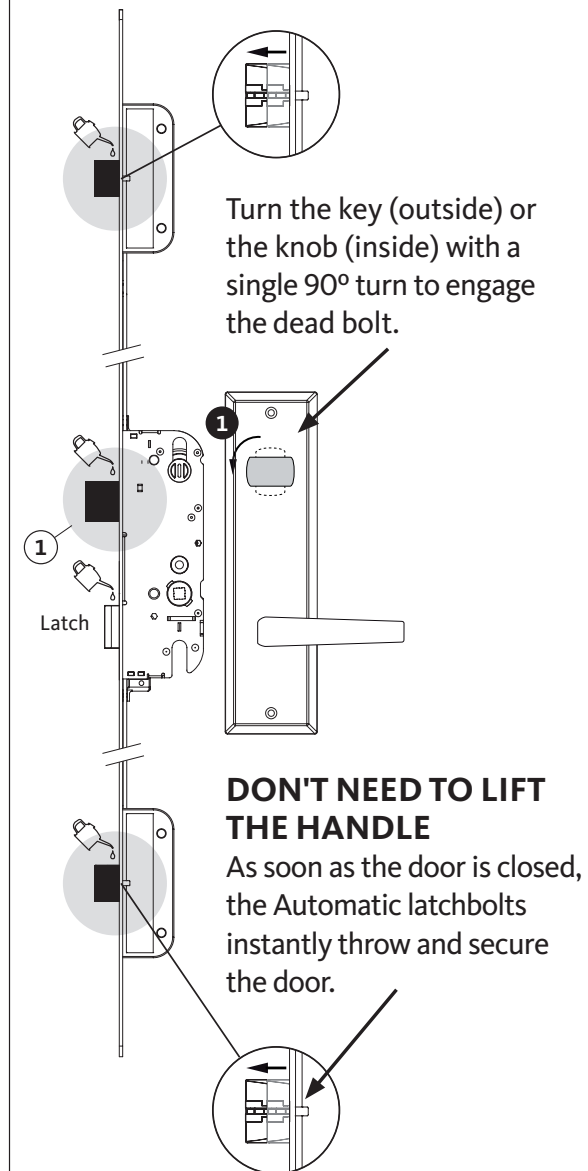



HANDLE TRIM

To prevent build-up of surface contaminants, possibly resulting in hardware surface deterioration; we recommend to wipe down with soft cloth all visible surfaces with warm water and mild soap. Then wipe the same surfaces with a clean cloth and warm water only and let surfaces dry completely.

For all finishes, it is strongly recommended to apply a non-abrasive automotive wax to protect the surface.

This procedure should be done a minimum of 2 times per year.

MULTIPOINT DOOR LOCKS

In order to ensure the smooth operation of the lock over a long period of time, it is necessary to lubricate all movable parts and locking points using acid and resin free lubricants.

The use of caustic cleansers or chemicals should be avoided.



Door Multi-point Locking System

Mounting and Installation Instructions For BERKELEY



FOLLOW THE CONVERSION INSTRUCTIONS THAT INCLUDED WITH THE KIT

**CONVERSION KIT
K-C2056-00-0-***

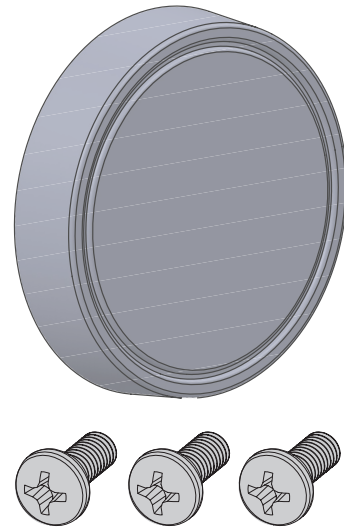

03
3

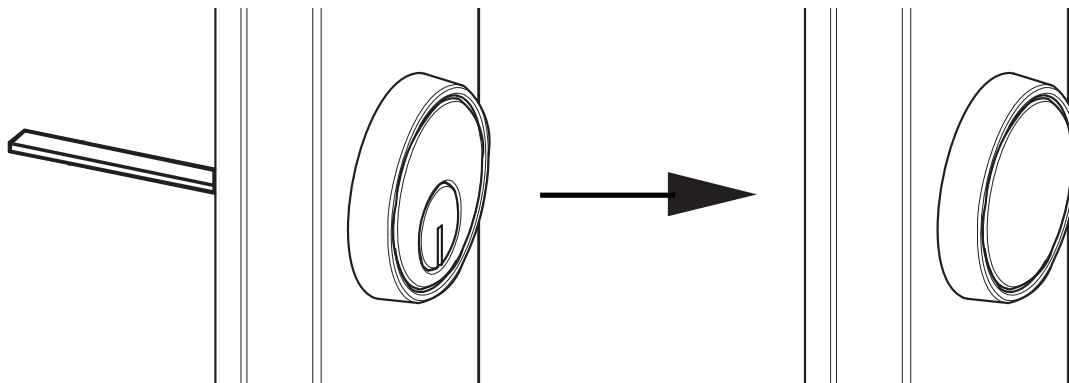

ACTIVE

DUMMY

Door Multi-point Locking System

Gripset Handle Dummy Conversion Instructions

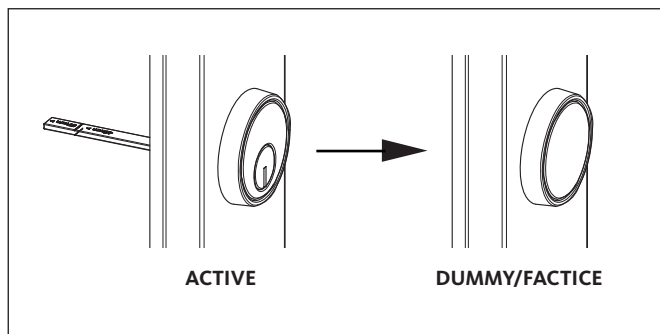
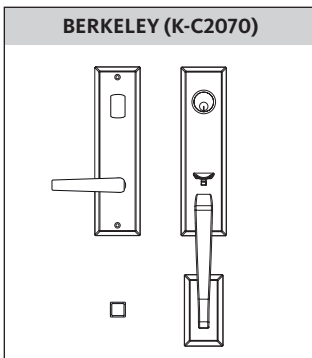

K-C2056-00-0-*

Conversion Kit

Pos	Description
①	3 M4 x 10mm screws
②	Dummy cylinder cover

Sachet de conversion

Pos	Description
①	3 vis M4 x 10mm
②	Cache de cylindre

INTERIOR PLATE

- ① Align mark on knob shank with screw hole (1A). Insert the two screws (1).

EXTERIOR PLATE

- ① Take out gasket. Insert the screw (1).
- ② Remove two screws from cylinder support, take out cylinder and cover. Place dummy cylinder cover, reinsert two screws and reposition the gasket.

PLAQUE INTÉRIEURE

- ① Aligner la marque sur le réceptacle de la queue de cylindre avec le trou de vis (1A). Insérer les deux vis (1).

PLAQUE EXTÉRIEURE

- ① Enlever le coupe-froid. Insérer la vis (1).
- ② Dévisser les deux vis du support de cylindre, enlever le cylindre et le cache. Placer le cache plein et reserrer les deux vis. Remettre le coupe-froid.

Door Multi-point Locking System

Gripset 1 3/4" Conversion Instructions

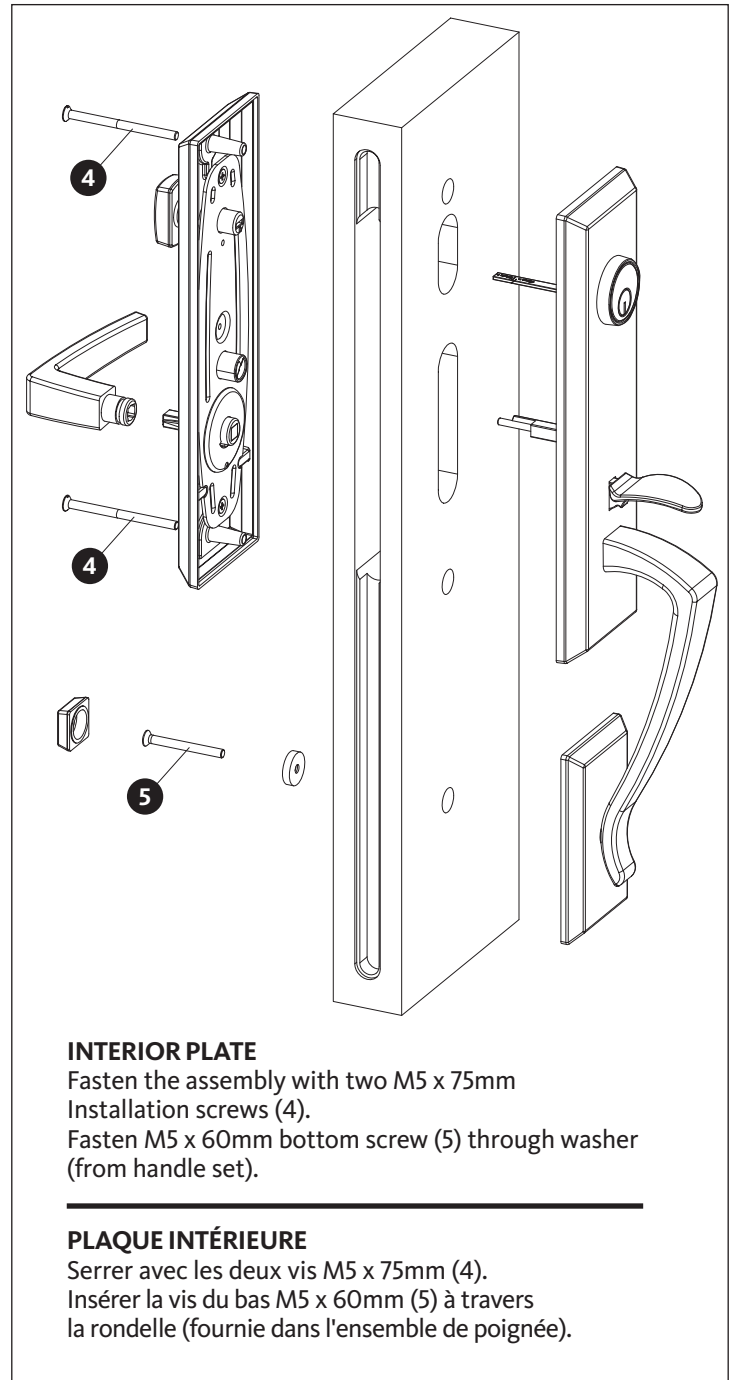
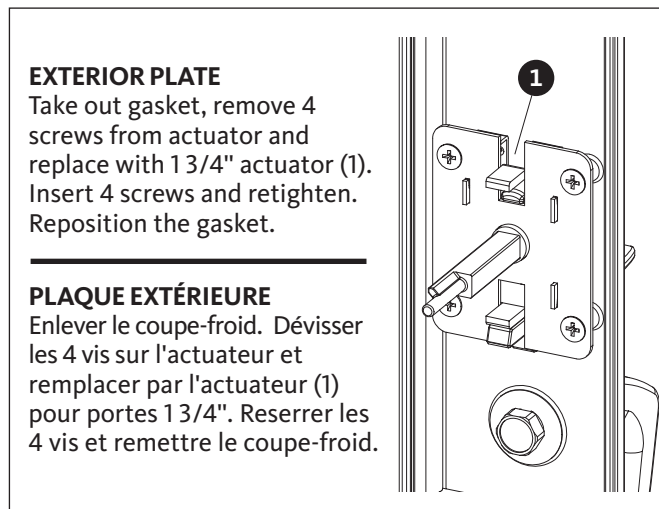
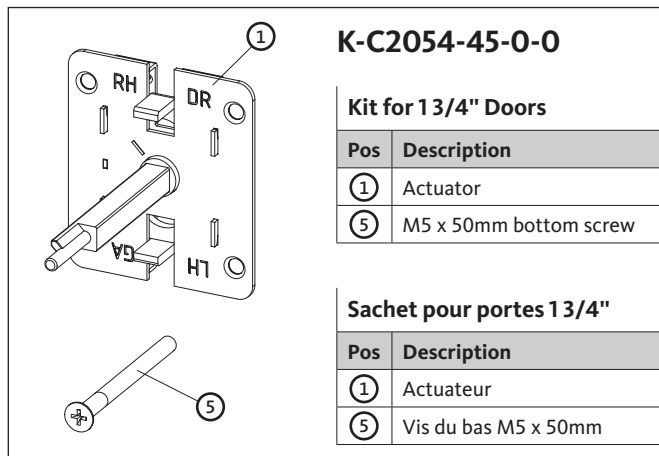
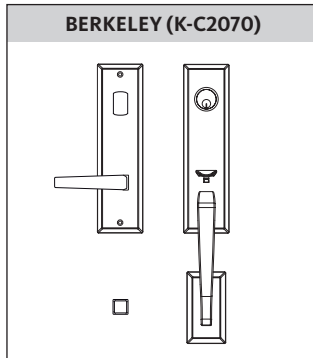

Door Multi-point Locking System

Gripset 2 1/4" Conversion Instructions

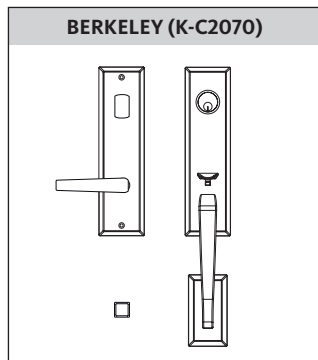

K-C2054-57-0-0

Kit for 2 1/4" Doors

Pos	Description
①	Actuator
⑤	M5 x 60mm bottom screw
④	M5 x 75mm bottom screw

Sachet pour portes 2 1/4"

Pos	Description
①	Actuateur
⑤	Vis du bas M5 x 60mm
④	Vis du bas M5 x 75mm

EXTERIOR PLATE
Take out gasket, remove 4 screws from actuator and replace with 2 1/4" actuator (1). Insert 4 screws and retighten. Reposition the gasket.

PLAQUE EXTÉRIEURE
Enlever le coupe-froid. Dévisser les 4 vis sur l'actuateur et remplacer par l'actuateur (1) pour portes 2 1/4". Reserrer les 4 vis et remettre le coupe-froid.

INTERIOR PLATE
Fasten the assembly with two M5 x 75mm Installation screws (4). Fasten M5 x 60mm bottom screw (5) through washer (from handle set).

PLAQUE INTÉRIEURE
Serrer avec les deux vis M5 x 75mm (4). Insérer la vis du bas M5 x 60mm (5) à travers la rondelle (fournie dans l'ensemble de poignée).

Door Multi-point Locking System

Gripset 2 3/4" Conversion Instructions



What's in the bag

Pos	Description
①	Actuator
②	Cylinder with long tail piece
③	M5 x 90mm installation screws (2)
④	M5 x 75mm bottom screw

IMPORTANT!
USE THE SCREWS SUPPLIED IN THIS BAG
TO FASTEN THE TRIM KIT AND
THE BOTTOM WASHER

03
3

STEP 1 Remove the gasket

STEP 2 Remove the 4 screws and the actuator

STEP 3 Install the 2 3/4" actuator and tighten the 4 screws

STEP 4 Remove the 2 screws from cylinder housing

STEP 5 Remove the cover and the cylinder

STEP 6 Install the supplied cylinder, tighten the 2 screws and reposition the gasket

Door Multi-point Locking System

Gripset 3" Conversion Instructions



What's in the bag

Pos	Description
①	Actuator
②	Cylinder with long tail piece
③	M5 x 90mm installation screws (2)
④	M5 x 75mm bottom screw

IMPORTANT!
USE THE SCREWS SUPPLIED IN THIS BAG
TO FASTEN THE TRIM KIT AND
THE BOTTOM WASHER

03
3

STEP 1 → Remove the gasket

STEP 2 → Remove the 4 screws and the actuator

STEP 3 → Install the 3" actuator and tighten the 4 screws

STEP 4 → Remove the 2 screws from cylinder housing

STEP 5 → Remove the cover and the cylinder

STEP 6 → Install the supplied cylinder, tighten the 2 screws and reposition the gasket



QUÉBEC / MARITIMES

Ferco Ferrures de Bâtiment Inc.
2000, Rue Berlier
Laval, QC H7L 4S4
Canada

T 450 973-1437
1 800 355-8810
F 450 973-7661
ferco@ferco.ca

ONTARIO / WESTERN PROVINCES

Ferco Architectural Hardware Inc.
T 905 282-9588
1 800 668-5310
F 905 282-9915

UNITED STATES

Ferco Architectural Hardware Inc.
T 1 800 927-1097
F 1 888 454-0161

www.ferco.ca