

Installation Guide for 65mm Active Trim Kit

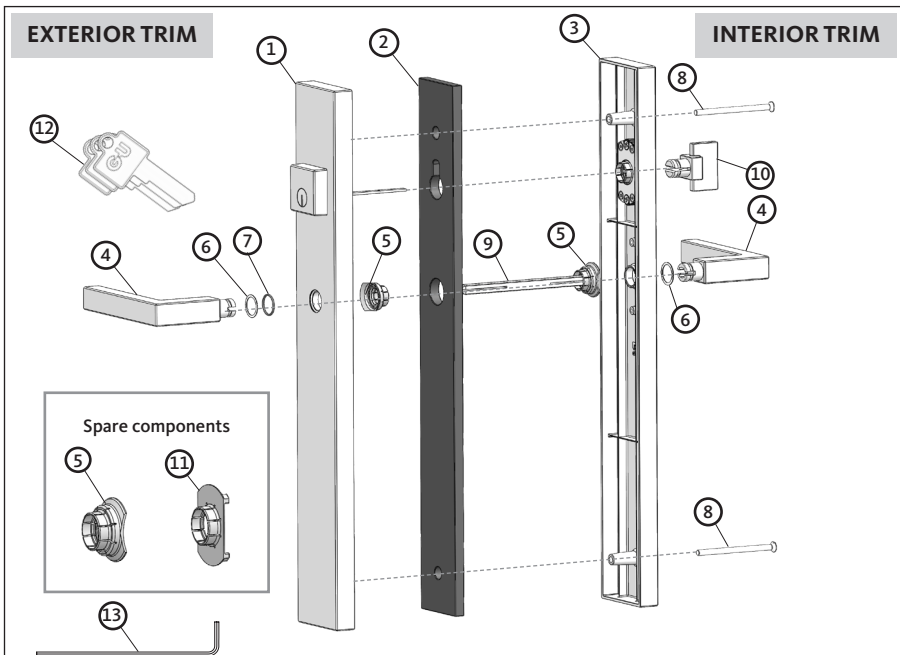

* LEFT HAND SHOWN *

Pos.	Description	Qty.
①	Exterior Plate 65 mm with US-cylinder	1
②	Gasket (on exterior plate)	1
③	Interior Plate 65 mm	1
④	Exterior/interior handles with set screws	2
⑤	Snap rings (need two for the assembly)	3
⑥	Nylon washers	2
⑦	"O" ring for exterior handle only	1
⑧	Installation screws M5 x 70mm for 1 3/4" (45mm) and 2 1/4" (57mm) thick doors	2
⑨	Spindle 8 x 8 x 120mm	1
⑩	BERLIN Knob	1
⑪	Snap collar (spare component)	1
⑫	Keys	3
⑬	Allen key	1

Handles Assembly Instructions

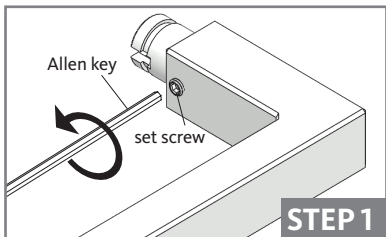

Loosen the set screws on both handles with the supplied Allen key.

ATTENTION!

Assemble at room temperature above 65° F. Place handle on soft cloth to avoid scratching.

Do not use mallet/hammer to snap ring in place, press with thumb.

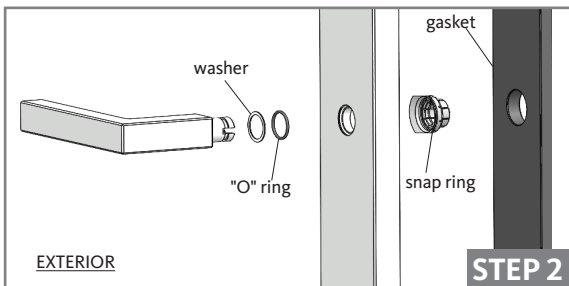

EXTERIOR TRIM ASSEMBLY

Remove the gasket. Place nylon washer and then the "O" ring on handle shank against lever. Slide handle shank into handle hole. From backplate, place snap ring over handle shank and press with thumb as shown. Re-install the gasket.

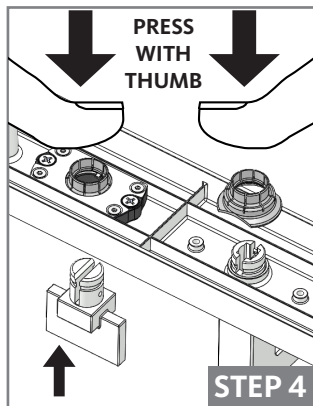

KNOB ASSEMBLY

Slide knob shank into the knob hole. Make sure that the mechanism flanges are aligned with the knob slot. From backplate, press on the snap collar with thumb as shown.

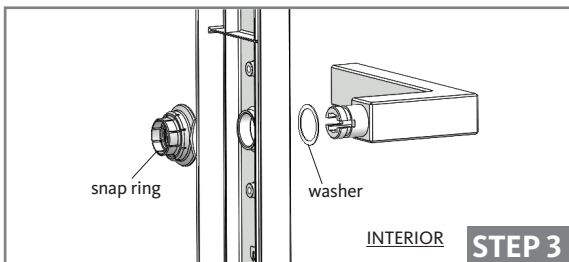

INTERIOR TRIM ASSEMBLY

Place nylon washer on handle shank against lever. Slide handle shank into handle hole. From backplate, place snap ring over handle shank and press with thumb as shown.

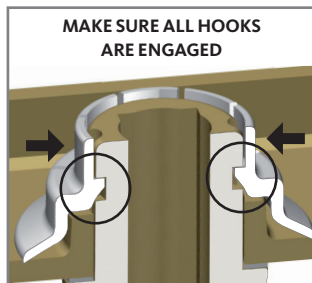

Trim Kit Installation Instructions

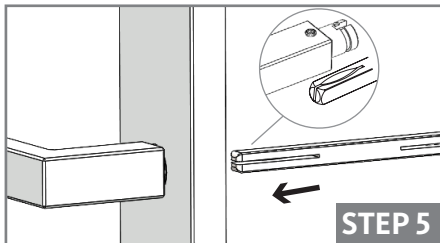

EXTERIOR TRIM

Slide spindle into handle square hole. The groove on the spindle should face the set screw as shown.

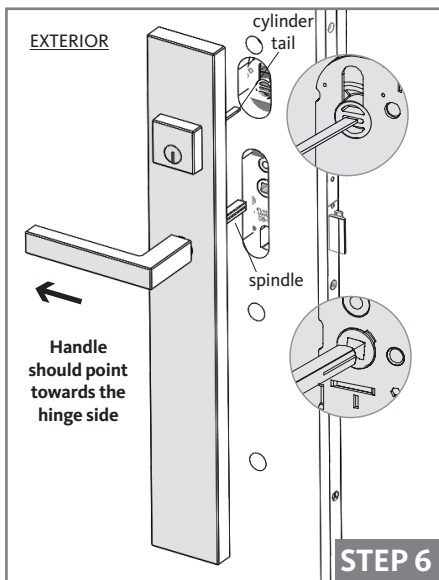

EXTERIOR TRIM INSTALLATION

Position the exterior trim into the holes, the cylinder tail (in horizontal position) through the cylinder bore and the spindle through the square hole on lockcase, and push the trim against the door.

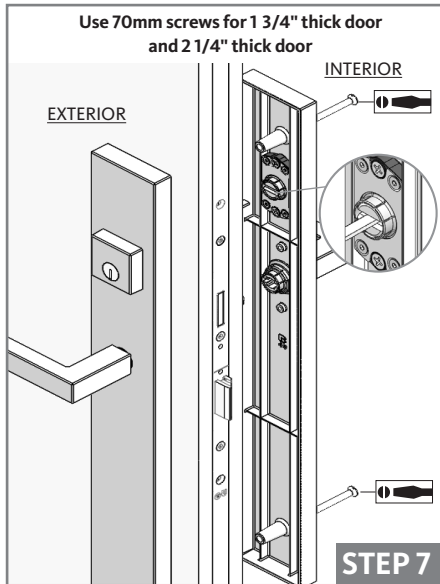

INTERIOR TRIM INSTALLATION

Hold the exterior trim, position the interior trim over the spindle and push the trims against the door. The cylinder tail piece should slide horizontally through knob slot. Fasten with two installation screws (use flat screwdriver). Don't fully tighten yet!

CHECK FUNCTION!

1. The operation of the handles.
2. The operation of the cylinder (outside with key, inside with knob), make sure the dead bolt extends a full 1", and retracts fully.
3. Be able to remove the key in locked position and in opened position.



Fully tighten the installation screws. Fully tighten the set screws on the levers.

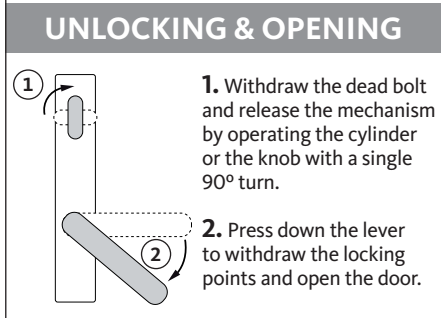
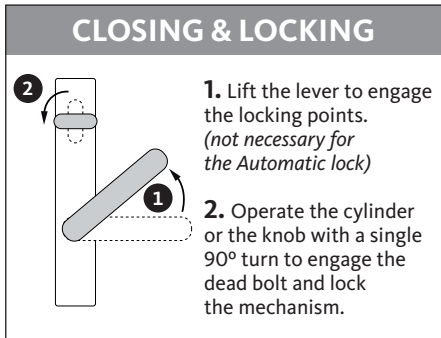
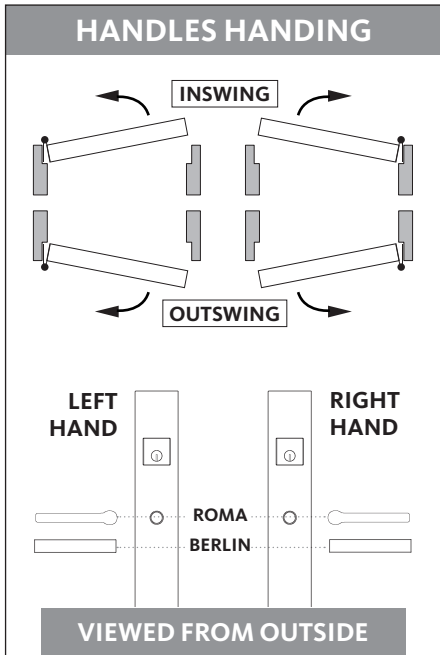

TROUBLESHOOTING

HANDLE IS HARD TO PRESS OR LIFT
 Although some tension is required to activate the mechanism, excessive force should not be required. Loosen the installation screws 1/4 turn at a time. Re-adjust the handle by unscrewing the set screw on one of the handles.

PLATES ARE NOT TIGHT AGAINST THE DOOR
 Installation screws are probably too long, file them down in short steps.

DEADBOLT IS HARD TO LOCK
 Cylinder tail piece may be too long, it may be pushing against the interior knob. To release this pressure, file the excess length in short steps.

CARE & MAINTENANCE

For use in a coastal or humid environments, add lithium grease on fixation screw to prevent galvanic corrosion over time

To prevent build-up of surface contaminants, possibly resulting in hardware surface deterioration and in some case appearance of rust; we recommend to wipe down with soft cloth all visible surfaces with warm water and mild soap. Then wipe the same surfaces with a clean cloth and warm water only and let surfaces dry completely. This procedure should be done a minimum of 2 times per year.

The use of caustic cleansers or chemicals should be avoided.

For all finishes except Oil Rubbed Bronze (05), it is strongly recommended to apply a non-abrasive automotive wax to protect the surface.

In order to ensure the smooth operation of the lock over a long period of time, it is necessary to lubricate all movable parts and locking points using acid and resin-free lubricants.

Ferco Architectural Hardware Inc.
 2000, Rue Berlier
 Laval QC H7L 4S4
 T 450.973.1437
 1.800.355.8810
 www.ferco.ca