



WINDOW TECHNOLOGY
DOOR TECHNOLOGY
AUTOMATIC ENTRANCE SYSTEMS
BUILDING MANAGEMENT SYSTEMS



WINDOW TECHNOLOGY – ORDER CATALOG | SECTION 01



Single & Double Hung Window Hardware



Securing technology for you







01

Single & Double Hung Window Hardware

Constant Force Balance.....	01.5
Support.....	01.7
Brake Shoes	01.8
Pivot Bars	01.9
Sash Locks And Keepers	01.10



Constant Force Balances and Monobloc Cassettes



Coil springs

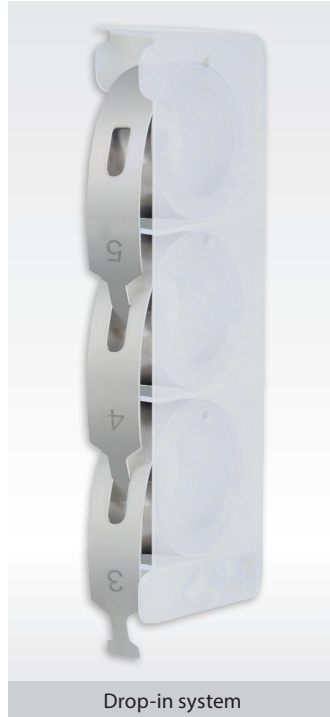

Drop-in system

Piggy-back Coil Springs

Description	Weight (lbs)	PU	Part Number
Coil springs	3.5	100	9-C1613-1C-0-0
		500	9-C1613-5C-0-0
	4.5	100	9-C1614-1C-0-0
		500	9-C1614-5C-0-0
	5.5	100	9-C1615-1C-0-0
		500	9-C1615-5C-0-0
	6.5	100	9-C1616-1C-0-0
		500	9-C1616-5C-0-0
	7.5	100	9-C1617-1C-0-0
		500	9-C1617-5C-0-0
	8.5	100	9-C1618-1C-0-0
		500	9-C1618-5C-0-0
	9.5	100	9-C1619-1C-0-0
		500	9-C1619-5C-0-0

PU = Packaging Unit

Additional information

- Stainless steel 304
- Weight range – 3 1/2 lbs to 9 1/2 lbs
- 1/2" coil spring for a 1.25" pocket
- Max. sash carrying capacity 57 lbs
- 35" travel
- Stamped with weight for easy identification
- Low cost and a reduction of inventory
- To be used with monobloc cassettes

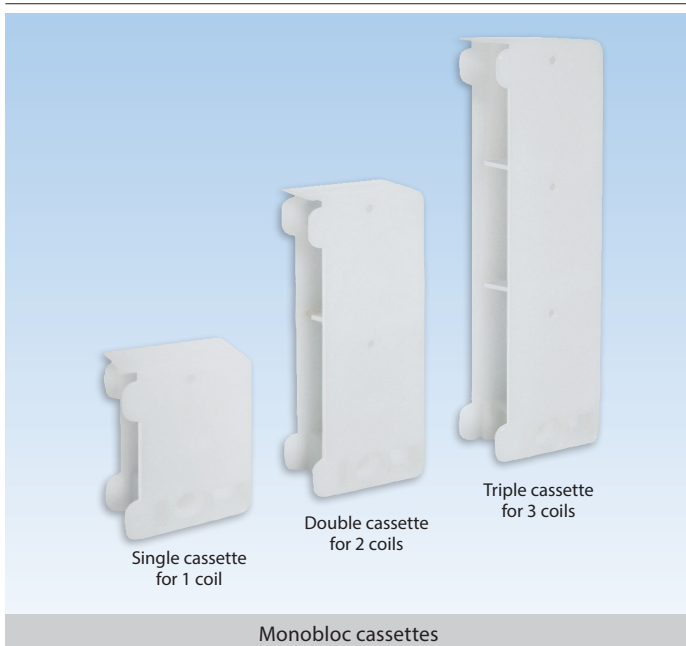

Single cassette for 1 coil

Double cassette for 2 coils

Triple cassette for 3 coils

Monobloc cassettes

Monobloc Cassettes for Piggy-back Coil Springs

Description	Color	PU	Part Number
Single cassette for 1 coil	White	200	9-C1521-2C-0-0
		1000	9-C1521-1M-0-0
Double cassette for 2 coils	White	200	9-C1522-2C-0-0
		1000	9-C1522-1M-0-0
Triple cassette for 3 coils	White	200	9-C1513-2C-0-0
		1000	9-C1513-8C-0-0

* = Color PU = Packaging Unit

Additional information

- Made of white acetal
- Can be combined with the tandem support for 3 coils
- Self locating coil tabs inside cassette
- Oversize spacers allow for extra coil room
- To be used with piggy-back coils spring

01

Pre-assembled coil Balances

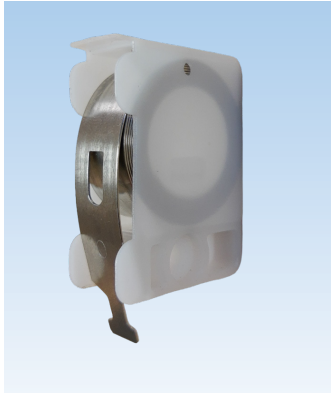

Simple Springs

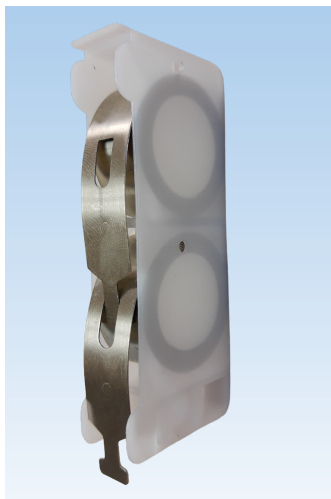

Double Spring



Triple Spring

Pre-assembled coil balances

Description	Weight (lbs)	PU	Part Number
Simple Spring	3.5	300	6-C1703-30-0-0
	4.5	300	6-C1704-30-0-0
	5.5	300	6-C1705-30-0-0
	6.5	300	6-C1706-30-0-0
	7.5	300	6-C1707-30-0-0
	8.5	300	6-C1708-30-0-0
	9.5	300	6-C1709-30-0-0
	10	300	6-C1710-30-0-0
Double Spring	11	250	6-C1711-25-0-0
	12	250	6-C1712-25-0-0
	13	250	6-C1713-25-0-0
	14	250	6-C1714-25-0-0
	15	250	6-C1715-25-0-0
	16	250	6-C1716-25-0-0
	17	250	6-C1717-25-0-0
	18	250	6-C1718-25-0-0
	19	250	6-C1719-25-0-0
	20	250	6-C1720-25-0-0
Triple Spring	21	150	6-C1721-15-0-0
	22	150	6-C1722-15-0-0
	23	150	6-C1723-15-0-0
	24	150	6-C1724-15-0-0
	25	150	6-C1725-15-0-0
	26	150	6-C1726-15-0-0
	27	150	6-C1727-15-0-0
	28	150	6-C1728-15-0-0
	29	150	6-C1729-15-0-0
	30	150	6-C1730-15-0-0

PU = Packaging Unit

Additional information

- Stainless steel 304
- Weight range – 3.5 lbs to 30 lbs
- 1/2" coil spring for a 1.25" pocket
- 35" travel

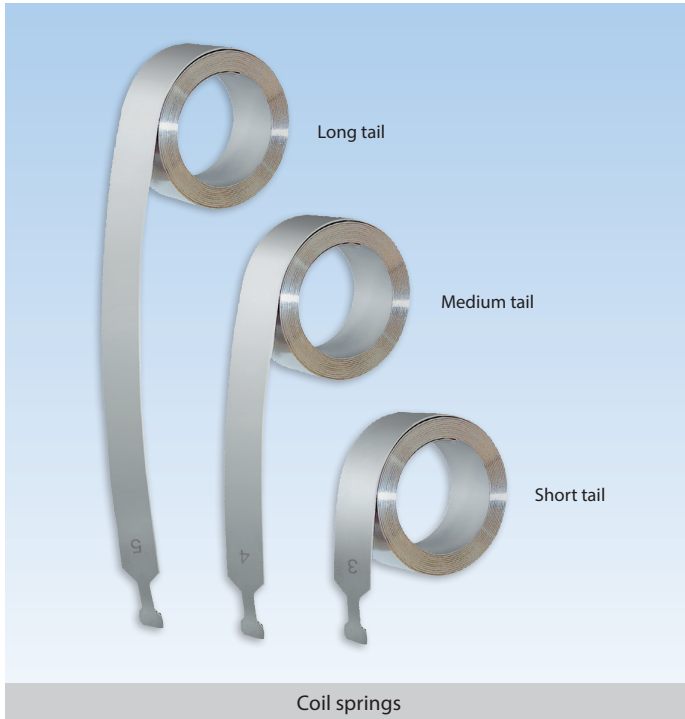

Additional information

- Stainless steel 304
- Weight range – 3 lbs to 9 lbs
- 1/2" coil spring for a 1.25" pocket
- Stamped with weight for easy identification
- To be used with monobloc cassettes or standard spring support

Coil Springs

Description	Weight (lbs)	PU	Part Number	
Coil with short tail	3*	100 500	9-C1531-1C-0-0 9-C1531-5C-0-0	
	4	100 500	9-C1541-1C-0-0 9-C1541-5C-0-0	
	5	100 500	9-C1551-1C-0-0 9-C1551-5C-0-0	
	6	100 500	9-C1561-1C-0-0 9-C1561-5C-0-0	
	7	100 500	9-C1571-1C-0-0 9-C1571-5C-0-0	
	8	100 500	9-C1581-1C-0-0 9-C1581-5C-0-0	
	9*	100 500	9-C1591-1C-0-0 9-C1591-5C-0-0	
	Coil with medium tail	3*	100 500	9-C1532-1C-0-0 9-C1532-5C-0-0
		4	100 500	9-C1542-1C-0-0 9-C1542-5C-0-0
5		100 500	9-C1552-1C-0-0 9-C1552-5C-0-0	
6		100 500	9-C1562-1C-0-0 9-C1562-5C-0-0	
7		100 500	9-C1572-1C-0-0 9-C1572-5C-0-0	
8		100 500	9-C1582-1C-0-0 9-C1582-5C-0-0	
9*		100 500	9-C1592-1C-0-0 9-C1592-5C-0-0	
Coil with long tail		3*	100 500	9-C1533-1C-0-0 9-C1533-5C-0-0
		4*	100 500	9-C1543-1C-0-0 9-C1543-5C-0-0
	5*	100 500	9-C1553-1C-0-0 9-C1553-5C-0-0	
	6*	100 500	9-C1563-1C-0-0 9-C1563-5C-0-0	
	7*	100 500	9-C1573-1C-0-0 9-C1573-5C-0-0	
	8*	100 500	9-C1583-1C-0-0 9-C1583-5C-0-0	
	9*	100 500	9-C1593-1C-0-0 9-C1593-5C-0-0	
	* Only available on special request		PU = Packaging Unit	



Support for Coil Springs

Description	Color	PU	Part Number
Support	White	200 1000	9-C1500-2C-0-0 9-C1500-1M-0-0
		* = Color	PU = Packaging Unit

Additional information

- Made of white acetal
- Can be combined with the tandem support for 3 coils
- To be used with constant force coils spring

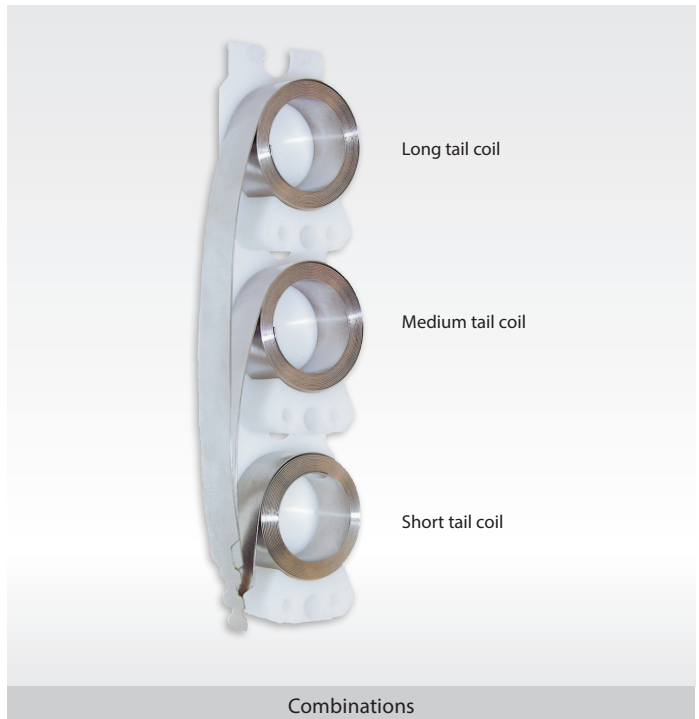



Sides Locking Brake Shoe

Description	Color	PU	Part Number
Brake Shoe	White	200	6-C1524-2C-0-0
		500	6-C1524-5C-0-0
		* = Color	PU = Packaging Unit

Additional information

- Brake shoe made of fiberglass reinforced nylon
- Spring slots closer to center of shoe to reduce torsion of shoe in track
- Reinforced spring slot designed to withstand greater pull force
- All edges are rounded to reduce friction
- Side locking shoe with metal brake
- Optional retainer clip (recommended)

01



Sides and Front Locking Brake Shoe

Description	Color	PU	Part Number
Brake Shoe	White	200	6-C1523-2C-0-0
		500	6-C1523-5C-0-0
		* = Color	PU = Packaging Unit

Additional information

- Brake shoe made of fiberglass reinforced nylon
- Spring slots closer to center of shoe to reduce torsion of shoe in track
- Reinforced spring slot designed to withstand greater pull force
- All edges are rounded to reduce friction
- Can be used for horizontal sliders
- Brake will engage with as little as 15° of sash turn
- Optional retainer clip (for horizontal sliders mandatory)



Mounted on brake shoe

Pivot Bar Retainer Clip

Description	Color	PU	Part Number
Retainer clip	White	200	9-C1512-2C-0-0
		1000	9-C1512-1M-0-0
		* = Color	PU = Packaging Unit

Pivot Bars and Dust Cover



Stainless Steel Pivot Bar

Description	Color	PU	Part Number
Pivot bar	SS	200 1000	9-C1504-2C-0-8 9-C1504-1M-0-8
* = Color		PU = Packaging Unit	

Additional information

- Made of stainless steel
- Use with brake shoe
- Use #6 x 12 pan screws



Zamac Pivot Bar

Description	Color	PU	Part Number
Pivot bar	Zamac	200 1000	9-C1507-2C-0-1 9-C1507-1M-0-1
* = Color		PU = Packaging Unit	

Additional information

- "Zamac" metal casting
- Use with brake shoe
- Use #6 x 12 pan screws

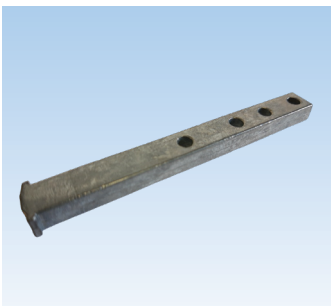

T-shaped Pivot Bar

Description	Color	PU	Part Number
Pivot bar	Zamac	200 1000	9-C1506-2C-0-0 9-C1506-1M-0-0
* = Color		PU = Packaging Unit	

Additional information

- "Zamac" metal casting
- Use with brake shoe
- Use #6 x 12 pan screws

Sash Locks and Keepers



Sash Lock

Description	Color	PU	Part Number
Sash lock	White	200	6-C1182-2C-0-7
* = Color		PU = Packaging Unit	

Additional information

- Sturdy zinc die cast construction
- Used with keepers:
9-C1184-2C-0-7
9-C1185-2C-0-7
9-C1186-2C-0-7

01



Keepers

Description	Color	PU	Part Number
Keeper 8.3mm width	White	200	9-C1184-2C-0-7
Keeper 6.5mm width	White	200	9-C1185-2C-0-7
Keeper 11.2mm width	White	200	9-C1186-2C-0-7
* = Color		PU = Packaging Unit	

Additional information

- Sturdy zinc die cast construction
- Used with locks:
6-C1182-2C-0-7
- Use #6 screws

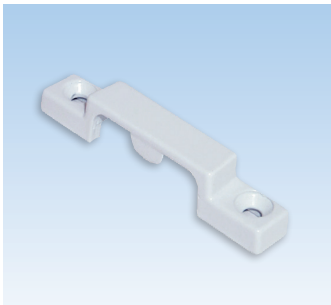
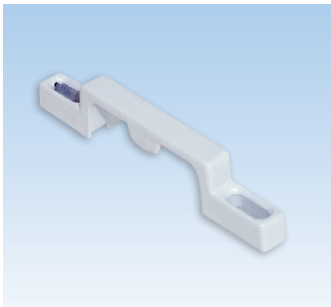

Sash Locks and Keepers

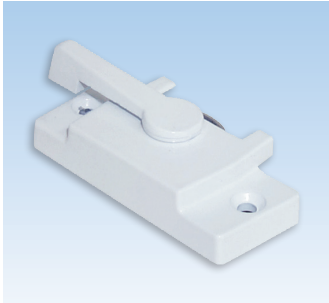

Sash Lock with Alignment Guides

Description	Color	PU	Part Number
Sash lock Dim. B = 11mm	White	200	6-C1181-2C-0-7
Sash lock Dim. B = 18mm	White	200	6-C1183-2C-0-7
* = Color		PU = Packaging Unit	

Additional information

- Sturdy zinc die cast construction
- Choice of two mounting hole locations:
6-C1181 (Dim. B = 11mm)
6-C1183 (Dim. B = 18mm)
- Alignment guides align lock to keeper perfectly and provide additional security
- Used with keepers:
9-C1181-2C-0-7
9-C1183-2C-0-7

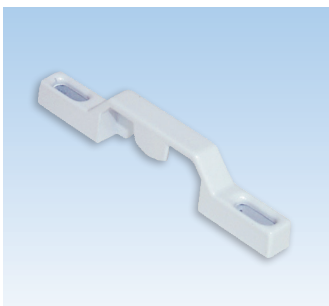
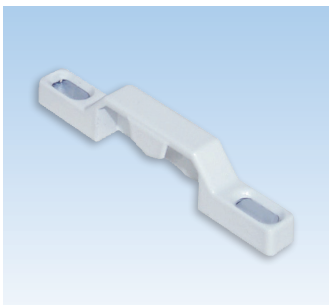

Keepers

Description	Color	PU	Part Number
Keeper 7.4mm width	White	200	9-C1181-2C-0-7
Keeper 6.5mm width	White	200	9-C1183-2C-0-7
* = Color		PU = Packaging Unit	

Additional information

- Sturdy zinc die cast construction
- Used with locks:
6-C1181-2C-0-7
6-C1183-2C-0-7
- Use #6 screws

Sash Locks and Keepers

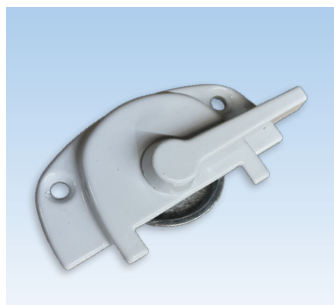

Sash Lock

Description	Color	PU	Part Number
Sash lock	White	200	6-C1173-2C-0-27
* = Color		PU = Packaging Unit	

Additional information

- Sturdy zinc die cast construction
- Used with keeper 9-C1173-2C-0-27

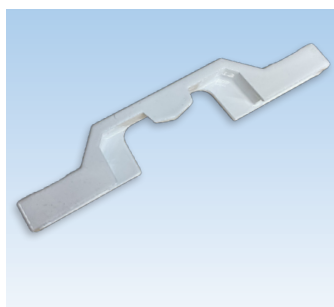

Keepers

Description	Color	PU	Part Number
Keeper 8.3mm width	White	200	9-C1173-2C-0-27
* = Color		PU = Packaging Unit	

Additional information

- Sturdy zinc die cast construction
- Used with locks:
6-C1173-2C-0-27
- Use #6 screws

01



WINDOW TECHNOLOGY
DOOR TECHNOLOGY
AUTOMATIC ENTRANCE SYSTEMS
BUILDING MANAGEMENT SYSTEMS

HEAD OFFICE

Ferco Architectural Hardware Inc.
2000, Berlier St.
Laval, QC H7L 4S4
Tel.: 450 973-1437
1 800 355-8810
Fax: 450 973-7661
ferco@ferco.ca

ONTARIO / WESTERN PROVINCES

Tel.: 905 282-9588
1 800 668-5310
Fax: 905 282-9915

UNITED STATES

Tel.: 1 800 927-1097
Fax: 1 888 454-0161

www.ferco.ca

Edition 01.2022 | Printed in Canada



Securing technology for you

