

ITEM	PART NUMBER	Description - FERCO	MATERIAL	QTY.
1	6-C7252-19-0-0	AMLOC	-	1
2	6-C7260-00-0-X	Faceplate kit AML	S.S. 304	1
3	6-C4400-12-0-1	Bottom rod	-	1
4	6-C4400-XX-0-1	Top rod (Refer to Catalog)	-	1
5	9-C0541-00-0-6	Integrated rod guide AMLOC	Nylon PA 6/6	2
6	9-C0550-00-0-6	Middle Guide AMLOC	Nylon PA 6/6	3

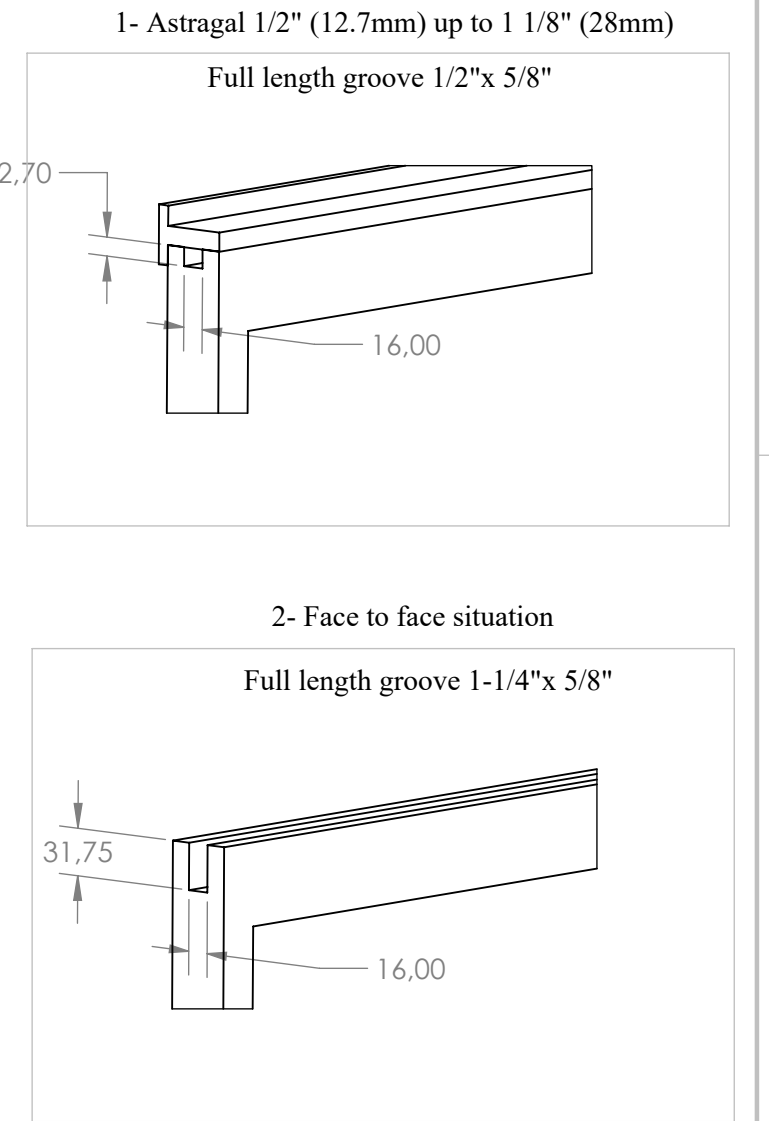

Notes:
RODS LENGTH CALCULATION:
 We recommend to use the 1200mm fixed length rod number 6-C4400-12-0-1 for the bottom rod. The center of astragal mortise lock will be located at 1280mm from bottom of door panel.

For the top rod, measure from the top measurement line to the top of the door panel. This will give you the top rod dimension.
 You may have to cut the rod to size to suit your door panel height

REFER TO CATALOG FOR AVAILABLE RODS SIZES

Applicable tolerances Dimensions X. : ±1 mm X.X : ±0.5 mm X.XX : ±0.15 mm Angles : ∠ ±1°	FERRURES DE BÂTIMENT INC. ARCHITECTURAL HARDWARE INC. LES INFORMATIONS CONTENUES DANS CE DESSIN SONT CONFIDENTIELLES ET SONT LA PROPRIÉTÉ EXCLUSIVE DE "FERCO FERRURES DE BÂTIMENT INC.". AUCUNE REPRODUCTION, UTILISATION, DISTRIBUTION OU VENTE À UN TIERS N'EST AUTORISÉE SANS LE CONSENTEMENT ÉCRIT DE "FERCO FERRURES DE BÂTIMENT INC." THE INFORMATION CONTAINED IN THIS DRAWING IS CONFIDENTIAL AND IS THE EXCLUSIVE PROPERTY OF "FERCO ARCHITECTURAL HARDWARE INC.". ANY REPRODUCTION, USE, DISTRIBUTION OR SALE TO A THIRD PARTY IS NOT AUTHORIZED WITHOUT THE WRITTEN CONSENT OF "FERCO ARCHITECTURAL HARDWARE INC."	Authentification	Fini / Finish	Numéro de pièce / Part number	No. Dessin / Drawing No.	Rev.
			-	6-C7252-19-0-0	D-2017-002-01	-
			Type of drawing	Description		
			Installation Drawing	Cutout - AMLOC		
			Normes dessin / Drawing standard	Préparé par / Prepared by :	Dessiné par / Drawing by :	Date : (DD/MM/YYYY)
			ANSI / ASTM	H.K.	H.K.	2020-02-04
				Éch. / Sc.	Format	Unit
				1:20	B	[in] mm
						Page
						1 of 1