



CONTENTS

D1 Screws	09.3
D4 Screws	09.3
H1 Screws	09.4
M1 Screws	09.4
M2 Screws	09.5
M3 Screws	09.5
B1 Screws	09.6
B2 Screws	09.6
B3 Screws	09.7
B5 Screws	09.7
B6 Screws	09.8
DD1 Screws	09.8
FS Screws	09.9
B5 Screws	09.9

GROUP 09

Drill Screws for Fixing Hardware to PVC Profiles



E-12562-XX-0-1

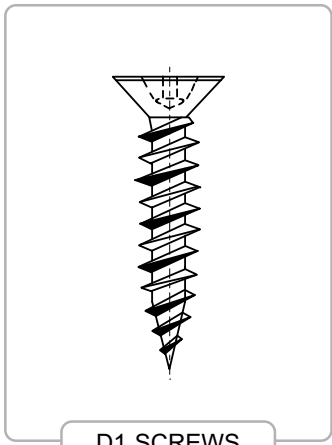

D1 SCREWS

Screws for hardware fixing

Type	Dim. mm	Color	Weight kg	PU	Part Number
D1	4,2 x 13	Zinc	0,8	1000	E-12562-13-0-1
D1	4,2 x 16	Zinc	0,9	1000	E-12562-16-0-1
D1	4,2 x 20	Zinc	1,1	1000	E-12562-20-0-1
D1	4,2 x 22	Zinc	1,2	1000	E-12562-22-0-1
D1	4,2 x 25	Zinc	1,4	1000	E-12562-25-0-1
D1	4,2 x 30	Zinc	1,6	1000	E-12562-30-0-1
D1	4,2 x 35	Zinc	1,9	1000	E-12562-35-0-1
D1	4,2 x 40	Zinc	2,2	1000	E-12562-40-0-1
D1	4,2 x 55	Zinc	3,1	1000	E-12562-55-0-1

* = Color PU = Packaging Unit

ADDITIONAL INFORMATION

- Type D1 with self-drilling spiral point and high duplex thread with Phillips socket
- Used for fastening fittings into semihard PVC at high speed



9-C991X-5M-0-1

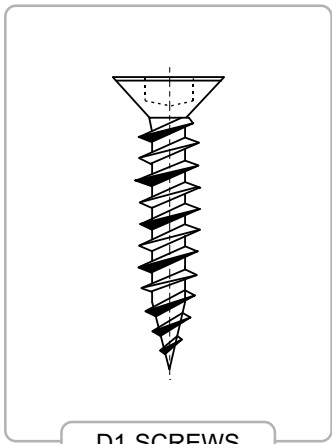

D1 SCREWS

"No corod" screws for hardware fixing

Type	Dim. mm	Color	Weight kg	PU	Part Number
D1	4,2 x 13	Zinc	0,8	5000	9-C9911-5M-0-1
D1	4,2 x 16	Zinc	0,9	5000	9-C9912-5M-0-1
D1	4,2 x 20	Zinc	1,1	5000	9-C9914-5M-0-1
D1	4,2 x 25	Zinc	1,4	5000	9-C9916-5M-0-1

* = Color PU = Packaging Unit

ADDITIONAL INFORMATION

- Type D1 with self-drilling spiral point and high duplex thread with Robertsons socket
- Used for fastening fittings into semihard PVC at high speed



H-00241-XX-0-*

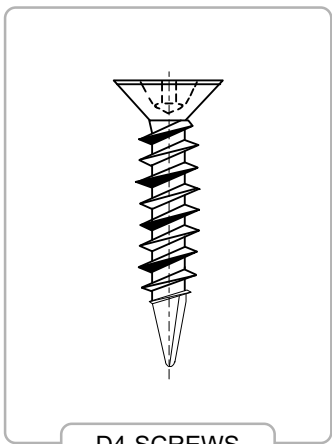

D4 SCREWS

Screws for hardware fixing

Type	Dim. mm	Color	Weight kg	PU	Part Number
D4	4,2 x 16	Zinc	0,9	1000	H-00241-16-0-1
D4	4,2 x 20	Zinc	1,1	1000	H-00241-20-0-1
D4	4,2 x 20	White head	1,1	1000	H-00241-20-0-7
D4	4,2 x 25	White head	1,4	1000	H-00241-25-0-7
D4	4,2 x 40	White head	2,3	1000	H-00241-40-0-7

* = Color PU = Packaging Unit

ADDITIONAL INFORMATION

- Type D4 with self-drilling symmetrical drill point and high duplex thread with Phillips socket
- Used for low speed fastening
- The special spade point minimizes the effort required when fixing

Drill Screws for Fixing Hardware to PVC Profiles



E-12566-XX-0-1

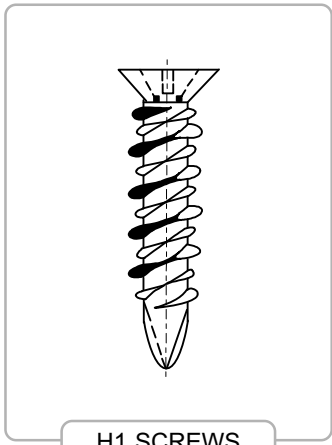

H1 SCREWS

Service screws

Type	Dim. mm	Color	Weight kg	PU	Part Number
H1	4,8 x 25	Zinc	1,7	1000	E-12566-25-0-1
H1	4,8 x 30	Zinc	2,0	1000	E-12566-30-0-1
H1	4,8 x 38	Zinc	2,7	1000	E-12566-38-0-1

* = Color PU = Packaging Unit

ADDITIONAL INFORMATION

- Type H1, as D1 except with 4,7 mm diameter for use as repair screw when screw D1 will not bite
- Phillips socket

Drill Screws for Fixing Hardware and Metal Reinforcement to PVC Profiles



E-12573-XX-0-1

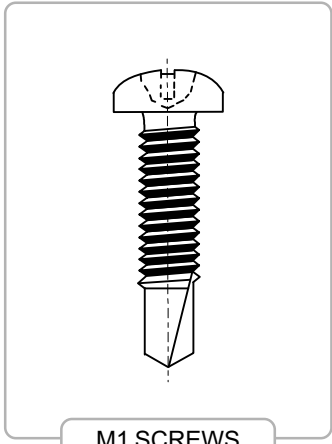

M1 SCREWS

Screws for fixing hardware and metal reinforcement

Type	Dim. mm	Color	Weight kg	PU	Part Number
M1	M4 x 13	Zinc	1,2	1000	E-12573-13-0-1
M1	M4 x 16	Zinc	1,8	1000	E-12573-16-0-1

* = Color PU = Packaging Unit

ADDITIONAL INFORMATION

- Type M1 with metric thread for controlled turning into multichamber profiles
- Long drill point
- Phillips socket
- Hardware fixing also in steel reinforcement up to 2 mm without predrilling

Drill Screws for Fixing Hardware to PVC Profiles

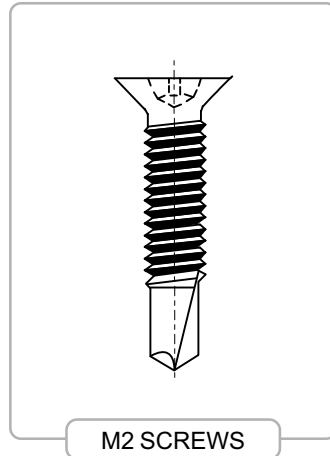

Screws for fixing hardware and metal reinforcement

Type	Dim. mm	Color	Weight kg	PU	Part Number
M2	M4 x 13	Zinc	0,9	1000	E-12575-13-0-1
M2	M4 x 16	Zinc	1,2	1000	E-12575-16-0-1
M2	M4 x 19	Zinc	1,5	1000	E-12575-19-0-1
M2	M4 x 22	Zinc	1,8	1000	E-12575-22-0-1
M2	M4 x 25	Zinc	2,0	1000	E-12575-25-0-1
M2	M4 x 32	Zinc	2,5	1000	E-12575-32-0-1
M2	M4 x 38	Zinc	2,9	1000	E-12575-38-0-1

* = Color

PU = Packaging Unit

ADDITIONAL INFORMATION

- Type M2 with drill point and metric thread
- Phillips socket
- Used for fastening steel or aluminium reinforcement of 1.5-3.5 mm thickness or for fastening fitting
- Especially recommended for fixing through several layer of PVC

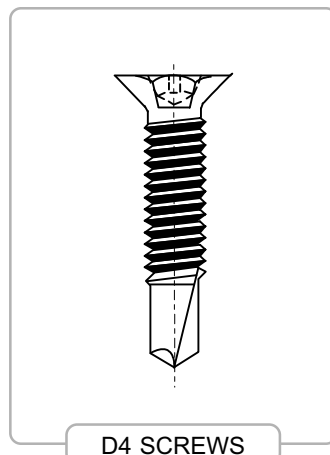

Screws for fixing hardware and metal reinforcement

Type	Dim. mm	Color	Weight kg	PU	Part Number
M3	M4 x 13	Zinc	0,9	1000	E-12574-13-0-1
M3	M4 x 16	Zinc	1,2	1000	E-12574-16-0-1
M3	M4 x 19	Zinc	1,5	1000	E-12574-19-0-1

* = Color

PU = Packaging Unit

ADDITIONAL INFORMATION

- Type M3, as M2 except with facets below the head for easier sinking of the screw head in thin-walled PVC profiles
- Phillips socket

Drill Screws for Fixing Hardware and Metal Reinforcement to PVC Profiles

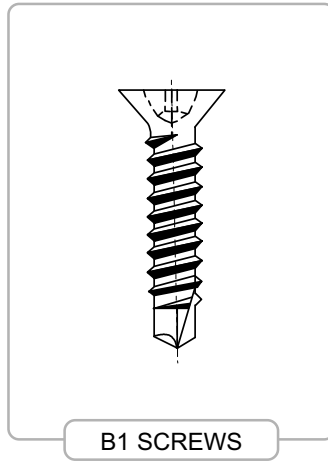

Screws for fixing hardware and metal reinforcement

Type	Dim. mm	Color	Weight kg	PU	Part Number
B1	3,9 x 13	Zinc	0,9	1000	E-12563-13-0-1
B1	3,9 x 16	Zinc	1,1	1000	E-12563-16-0-1
B1	3,9 x 19	Zinc	1,3	1000	E-12563-19-0-1
B1	3,9 x 22	Zinc	1,5	1000	E-12563-22-0-1
B1	3,9 x 25	Zinc	1,7	1000	E-12563-25-0-1
B1	3,9 x 32	Zinc	2,1	1000	E-12563-32-0-1
B1	3,9 x 38	Zinc	2,6	1000	E-12563-38-0-1

* = Color

PU = Packaging Unit

ADDITIONAL INFORMATION

- Type B1 with drill point and ribbed self countersinking head
- Phillips socket
- Used for fastening steel and aluminium reinforcement of up to 1.5 mm thickness
- Suitable where the reinforcement lies close to the PVC profiles

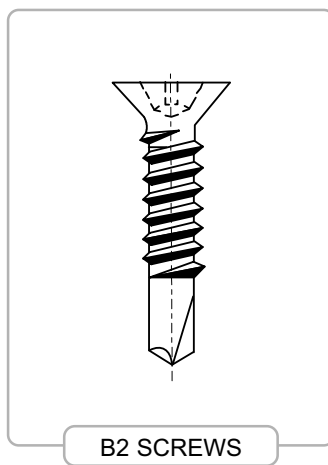

Screws for fixing hardware and metal reinforcement

Type	Dim. mm	Color	Weight kg	PU	Part Number
B2	3,9 x 16	Zinc	1,0	1000	E-12569-16-0-1
B2	3,9 x 19	Zinc	1,2	1000	E-12569-19-0-1

* = Color

PU = Packaging Unit

ADDITIONAL INFORMATION

- Type B2, as B1 except longer drill point to prevent too early fix to PVC
- Phillips socket
- Fixing metal reinforcement with larger gap between reinforcement and PVC outside wall

Drill Screws for Fixing Hardware and Metal Reinforcement to PVC Profiles

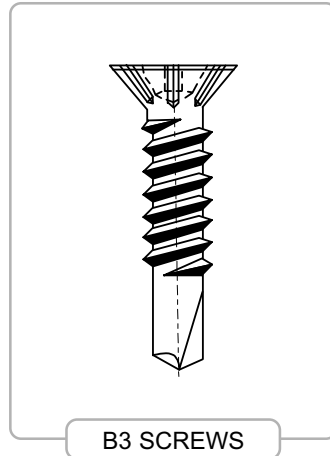

Screws for fixing hardware and metal reinforcement

Type	Dim. mm	Color	Weight kg	PU	Part Number
B3	3,9 x 16	Zinc	1,0	1000	E-12571-16-0-1
B3	3,9 x 19	Zinc	1,2	1000	E-12571-19-0-1

* = Color PU = Packaging Unit

ADDITIONAL INFORMATION

- Type B3, as B2 except with ribs under the head: eases the countersinking of the screw head with thin walled steel profiles which lie directly under the PVC wall
- Phillips socket

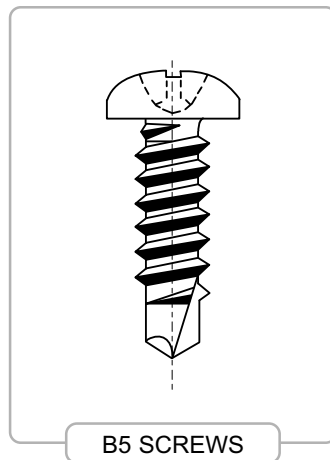

Screws for fixing hardware and metal reinforcement

Type	Dim. mm	Color	Weight kg	PU	Part Number
B5	3,9 x 13	Zinc	1,2	1000	H-00242-13-0-1
B5	3,9 x 19	Zinc	1,7	1000	H-00242-19-0-1

* = Color PU = Packaging Unit

ADDITIONAL INFORMATION

- Type B5 with drill point and domed head for fastening steel and aluminium reinforcement up to 2.5 mm thickness
- Suitable where the reinforcement lies close to the PVC profile
- Phillips socket

Drill Screws for Fixing Hardware and Metal Reinforcement to PVC Profiles



H-00239-XX-0-1

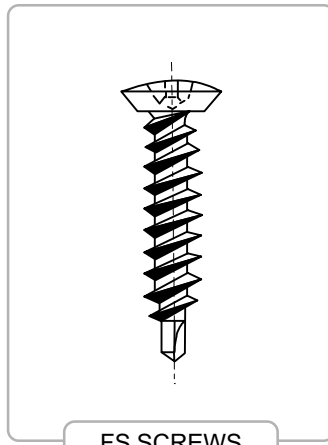

FS SCREWS

Screws for fixing hardware and metal reinforcement

Type	Dim. mm	Color	Weight kg	PU	Part Number
FS	4,8 x 13	Zinc	0,8	1000	H-00239-13-0-1
FS	4,8 x 16	Zinc	1,0	1000	H-00239-16-0-1
FS	4,8 x 23	Zinc	1,4	1000	H-00239-23-0-1

* = Color PU = Packaging Unit

ADDITIONAL INFORMATION

- Type FS with self-drilling symmetrical point
- The FS screw has been especially designed for installation of hardware in thin materials (e.g. friction stays)
- Phillips socket

Drill Screws for General Fixing to PVC Profiles



E-12576-XX-0-*

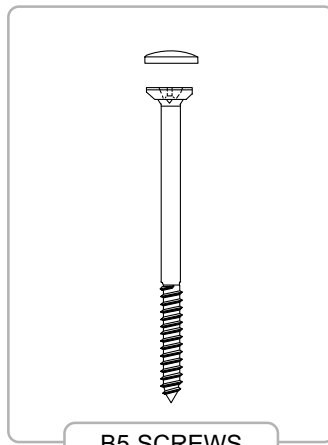

B5 SCREWS

Coupling screws for windows and doors

Type	Dim. mm	Color	Weight kg	PU	Part Number
B5	4,8 x 55	Zinc	3,5	1000	E-12576-55-0-3
B5	4,8 x 65	Zinc	4,0	1000	E-12576-65-0-3
B5	4,8 x 80	Zinc	4,8	1000	E-12576-80-0-3
B5	4,8 x 95	Zinc	5,2	1000	E-12576-95-0-3

Cover		PU	Part Number
Cover for B5 screws	Brown	1000	H-00396-00-0-5
	Black	1000	H-00396-00-0-6
	White	1000	H-00396-00-0-7

* = Color PU = Packaging Unit

ADDITIONAL INFORMATION

- Type B5 threaded for sheet metal
- Phillips socket
- Cap head (not included)
- Predrill 4 mm diameter